

Electric Cooker Models 8SSMS, 8BC and 8C Installation, Operation, Service, and Parts Manual

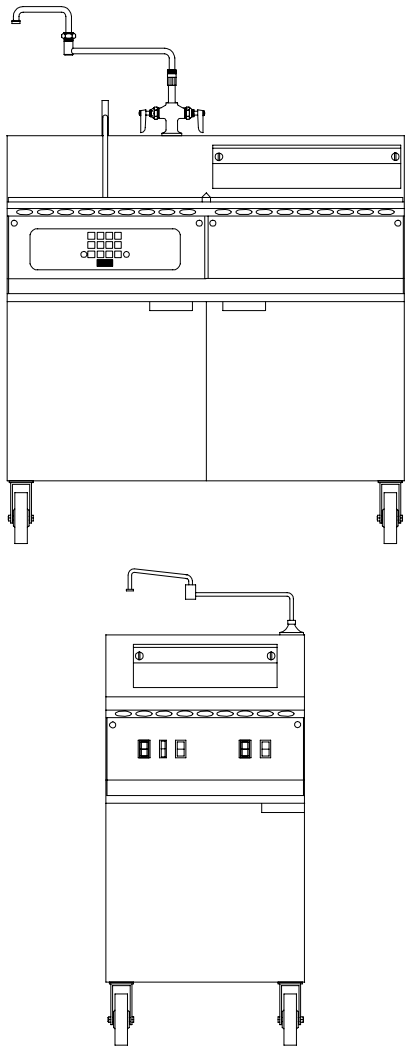

Frymaster, a member of the Commercial Food Equipment Service Association, recommends using CFESA Certified Technicians.

24-Hour Service Hotline 1-800-551-8633

MAR 11
* 8195246 *

**THIS EQUIPMENT IS INTENDED FOR INDOOR USE ONLY.
DO NOT INSTALL OR OPERATE THIS EQUIPMENT IN OUTDOOR AREAS.**

DO NOT OPERATE THIS EQUIPMENT WITHOUT FIRST READING THIS MANUAL.

DO NOT OPERATE THIS EQUIPMENT UNLESS ALL COVERS AND ACCESS PANELS ARE IN PLACE AND PROPERLY SECURED.

DO NOT ATTEMPT TO REPAIR OR REPLACE ANY COMPONENT OF THIS EQUIPMENT UNLESS ALL POWER TO THE UNIT HAS BEEN DISCONNECTED.

IF THE POWER SUPPLY CORD IS DAMAGED, IT MUST BE REPLACED BY THE MANUFACTURER OR ITS SERVICE AGENT OR SIMILARLY QUALIFIED PERSONS IN ORDER TO AVOID A HAZARD.

USE CAUTION WHEN SETTING UP, OPERATING, OR CLEANING THIS EQUIPMENT TO AVOID CONTACT WITH HEATED SURFACES.

DO NOT USE WATER JETS TO CLEAN THIS EQUIPMENT.

THIS EQUIPMENT IS TO BE INSTALLED IN COMPLIANCE WITH THE BASIC PLUMBING CODE OF THE BUILDING OFFICIALS AND CODE ADMINISTRATORS INTERNATIONAL, INC. (BOCA) AND THE FOOD SERVICE SANITATION MANUAL OF THE FOOD AND DRUG ADMINISTRATION.



DANGER

IMPROPER INSTALLATION, ADJUSTMENT, ALTERATION, SERVICE, OR MAINTENANCE CAN CAUSE PROPERTY DAMAGE, INJURY, OR DEATH. READ THE INSTALLATION, OPERATING, AND SERVICE INSTRUCTIONS THOROUGHLY BEFORE INSTALLING OR SERVICING THIS EQUIPMENT.



DANGER

FOR YOUR SAFETY, DO NOT STORE OR USE GASOLINE OR OTHER FLAMMABLE LIQUIDS OR VAPORS IN THE VICINITY OF THIS OR ANY OTHER APPLIANCE.

COMPUTERS
FCC

This device complies with Part 15 of the FCC rules. Operation is subject to the following two conditions:

1) This device may not cause harmful interference, and 2) This device must accept any interference received, including interference that may cause undesired operation. While this device is a verified Class A device, it has been shown to meet the Class B limits.

CANADA

This digital apparatus does not exceed the Class A or B limits for radio noise emissions as set out by the ICES-003 standard of the Canadian Department of Communications.

Cet appareil numérique n'émet pas de bruits radioélectriques dépassant les limites de classe A et B prescrites dans la norme NMB-003 édictée par le Ministre des Communications du Canada.



DANGER

THIS PRODUCT CONTAINS CHEMICALS KNOWN TO THE STATE OF CALIFORNIA TO CAUSE CANCER AND/OR BIRTH DEFECTS OR OTHER REPRODUCTIVE HARM.

Operation, installation, and servicing of this product could expose you to airborne particles of glasswool or ceramic fibers, and/or crystalline silica. Inhalation of airborne particles of glasswool or ceramic fibers is known to the State of California to cause cancer.

**FRYMASTER FRYERS EQUIPPED WITH LEGS ARE FOR PERMANENT INSTALLATION. FOR MOVEABLE OR PORTABLE INSTALLATION, FRYMASTER OPTIONAL EQUIPMENT CASTERS MUST BE USED.
QUESTIONS??? CALL 1-800-551-8633.**

Do not use deliming solution to clean water bath units. Use of deliming solution will damage all stainless steel parts.

ELECTRIC COOKERS 8SMS, 8BC AND 8C

TABLE OF CONTENTS

CHAPTER 1: General Information

1.1	Parts Ordering and Service Information	1-1
1.2	Safety Information	1-1
1.3	Equipment Description	1-2
1.4	Installation, Operating, and Service Personnel	1-2
1.5	Definitions.....	1-3
1.6	Shipping Damage Claim Procedure.....	1-3

CHAPTER 2: Installation Instructions

2.1	General Installation Requirements.....	2-1
2.2	Caster/Leg Installation	2-2
2.3	Pre-Connection Preparations	2-2
2.4	Connecting to the Electrical Power Supply	2-3
	Field Connection Wiring Diagrams	2-4

CHAPTER 3: Operating Instructions

3.1	Introduction.....	3-1
3.2	Operating Instructions.....	3-2
3.3	Shutting the Cooker Down.....	3-2
3.4	Boiling Out the Cookpot.....	3-3

CHAPTER 4: Preventive Maintenance

4.1	Daily Preventive Maintenance.....	4-1
4.2	SMS II Controller Simmer Mode Adjustment.....	4-2

CHAPTER 5: Operator Troubleshooting

5.1	Introduction.....	5-1
5.2	Operator Troubleshooting Guides.....	5-2
5.3	Replacing the Controller or Controller Wiring Harness	5-3
5.4	Replacing Fuses	5-4

CHAPTER 6: Service Procedures

6.1	Functional Description of Electric Cookers 8SMS, 8BC, and 8C	6-1
6.2	Accessing Equipment for Servicing.....	6-2
6.3	Replacing Equipment Components.....	6-2
6.3.1	Replacing the Controller	6-2
6.3.2	Replacing the Transformer, Basket Lift Relay, Contactor, or Solenoid Valve	6-2
6.3.3	Replacing the Element	6-3
6.3.4	Replacing the High-Limit Thermostat	6-4
6.3.5	Replacing a Water Level Sensor or the Temperature Probe.....	6-5
6.3.6	Replacing the Pressure Regulator	6-6
6.3.7	Replacing the Water Faucet	6-7
6.3.8	Replacing the Cookpot or Rinse Tank	6-8
6.3.9	Replacing the Basket Lift Motor and Related Components	6-10

6.4	Troubleshooting	6-11
6.4.1	How the Autofill System Works.....	6-11
6.4.2	How the Water Heating System Works.....	6-11
6.4.3	Technician Troubleshooting Guides.....	6-12
	Troubleshooting the Autofill System.....	6-12
	Troubleshooting the Basket Lift	6-13
	Troubleshooting the Controller.....	6-14
	Troubleshooting the Contactor Coil.....	6-15
	Troubleshooting the High-Limit Thermostat.....	6-15
	Troubleshooting the Temperature Probe	6-15
6.5	Wiring Diagrams.....	6-16

CHAPTER 7: Parts List

7.1	Accessories	7-1
7.2	Basket Lift Components	7-2
7.3	Cabinetry.....	7-4
7.4	Cookpot and Rinse Tank Components	7-6
7.5	Electrical Components and Controllers	7-8
7.6	Water Supply Components	7-9

ELECTRIC COOKERS 8SMS, 8BC AND 8C

CHAPTER 1: GENERAL INFORMATION

1.1 Parts Ordering and Service Information

In order to assist you as quickly as possible, the Factory Authorized Servicer (FAS) or Service Department representative requires certain information about your equipment. Most of this information is printed on a data plate affixed to the inside of the door.

Parts orders may be placed directly with your local FAS or distributor. A list of Frymaster Factory Authorized Servicers (FAS's) is located on the Frymaster website at www.frymaster.com. If you do not have access to this list, contact the Frymaster Technical Service Department at 1-800-551-8633 or 1-318-865-1711.

When ordering parts, the following information is required:

Model Number: _____
Serial Number: _____
Voltage: _____
Item Part Number: _____
Quantity Needed: _____

Service information may be obtained by contacting your local FAS/Distributor. Information may also be obtained by calling the Frymaster Technical Service Department at 1-800-551-8633 or 1-318-865-1711. When requesting service, please have the following information ready:

Model Number: _____
Serial Number: _____
Voltage: _____

In addition to the model number, serial number, and voltage, please be prepared to describe the nature of the problem and have ready any other information that you think may be helpful in solving your problem.

RETAIN AND STORE THIS MANUAL IN A SAFE PLACE FOR FUTURE USE.

1.2 Safety Information

Before attempting to operate your unit, read the instructions in this manual thoroughly.

Throughout this manual, you will find safety notations enclosed in boxes similar to the ones illustrated below and on the following page.

 CAUTION
CAUTION boxes contain information about actions or conditions that <i>may cause or result in malfunction of your equipment.</i>

 **WARNING**

WARNING boxes contain information about actions or conditions that *may cause or result in damage to your equipment*, and which may cause your equipment to malfunction.

 **DANGER**

DANGER boxes contain information about actions or conditions that *may cause or result in injury to personnel*, and which may cause damage or malfunctioning of your equipment

1.3 Equipment Description

Frymaster Electric Cookers are specifically designed to deliver high volumes of cooked or blanched food automatically.

Model Comparison:

8SMS: The “Spaghetti Magic System” features an 8-kilowatt cooker and rinse tank combination. The 8.7-gallon (33-liter) cooker is equipped with a programmable computer that controls water temperature, water level, and cooking times. A swing-away water faucet is standard. Its automatic basket lift system submerges and extracts either bulk or individualized portions of pasta according to times programmed by the operator. Options include automatic water filling (AutoFill) and starch skimming (AutoSkim). The AutoFill feature maintains the cookpot water level approximately 1¼ inch (32mm) below the overflow drain. The AutoSkim feature sprays water onto the surface of the water, forcing starch to the overflow drain. This eliminates loss of cooking time associated with removing excess starch buildup. It also keeps the cooking water at the optimum level by replacing water evaporated during the cooking process. The AutoSkim function also saves energy since there is no need to reheat a refilled cookpot. The cookpot is safeguarded against over filling and boilover by a large overflow drain. “SD” following the model designation indicates a stainless steel cookpot and door, and an enameled cabinet. “SC” following the model designation indicates all stainless steel components.

8BC & 8C: These standalone cookers are essentially the same as the 8SMS, but without the built-in rinse tank. *8BC* models have an automatic basket lift and optional automatic water filling and starch skimming. *8C* models have no basket lifts and no automatic water filling and starch skimming options. The cookpot in both is safeguarded against over filling and boilover by a large overflow drain. “SD” following the model designation indicates a stainless steel cookpot and door, and an enameled cabinet. “SC” following the model designation indicates all stainless steel components.

1.4 Installation, Operating, and Service Personnel

Operating information for Frymaster equipment is intended for use by qualified and/or authorized personnel only, as defined in Section 1.5.

All installation and service on Frymaster equipment must be performed by qualified, certified, licensed, and or/authorized installation or service personnel, as defined in Section 1.5.

1.5 Definitions

QUALIFIED AND/OR AUTHORIZED OPERATING PERSONNEL

Qualified/authorized operating personnel are those who have carefully read the information in this manual and have familiarized themselves with the equipment functions, or who have had previous experience with the operation of the equipment covered in this manual.

QUALIFIED INSTALLATION PERSONNEL

Qualified installation personnel are individuals, or firms, corporations, or companies that, either in person or through a representative, are engaged in and are responsible for the installation of electrical appliances. Qualified personnel must be experienced in such work, be familiar with all electrical precautions involved, and have complied with all requirements of applicable national and local codes.

QUALIFIED SERVICE PERSONNEL

Qualified service personnel are those who are familiar with Frymaster equipment and who are authorized by Frymaster to perform service on Frymaster equipment. All authorized service personnel are required to maintain a complete set of service and parts manuals and to stock a prescribed minimum amount of Frymaster parts. *Failure to use qualified service personnel will void the Frymaster Warranty on your equipment.*

1.6 Shipping Damage Claim Procedure

Your Frymaster equipment was carefully inspected and packed before leaving the factory. The transportation company assumes full responsibility for safe delivery upon acceptance of the equipment for transport.

What to do if your equipment arrives damaged:

1. **File a claim for damages immediately**, regardless of the extent of damages.
2. **Inspect for and record all visible loss or damage** and ensure that this information is noted on the freight bill or express receipt and is signed by the person making the delivery.
3. **Concealed loss or damage** that was unnoticed until the equipment was unpacked should be recorded and reported to the freight company or carrier **immediately** upon discovery. A concealed damage claim must be submitted within 15 days of the date of delivery. Ensure that the shipping container is retained for inspection.

**FRYMASTER DOES NOT ASSUME RESPONSIBILITY
FOR DAMAGE OR LOSS INCURRED IN TRANSIT.**

ELECTRIC COOKERS 8SMS, 8BC AND 8C

CHAPTER 2: INSTALLATION INSTRUCTIONS

2.1 General Installation Requirements

PROPER INSTALLATION IS ESSENTIAL FOR EFFICIENT, TROUBLE-FREE OPERATION OF YOUR COOKER. ANY UNAUTHORIZED ALTERATIONS MADE TO THIS EQUIPMENT WILL VOID THE FRYMASTER WARRANTY.

Upon arrival, inspect the equipment carefully for visible or concealed damage. (See **Shipping Damage Claim Procedure** in Chapter 1.)

NATIONAL CODE REQUIREMENTS

This equipment is to be installed in compliance with the Basic Plumbing Code of the Building Officials and Code Administrators International, Inc. (BOCA) and the Food Service Sanitation Manual of the U.S. Food and Drug Administration.

ELECTRICAL GROUNDING REQUIREMENTS

All electrically operated appliances must be grounded in accordance with all applicable national and local codes. A wiring diagram is located on the inside of the equipment door. Refer to the rating plate on the inside of the door for proper voltages.

FCC COMPLIANCE

The user is cautioned that any changes or modifications to Frymaster computers not expressly approved by the party responsible for compliance could void the user's authority to operate the equipment. Frymaster computers have been tested and found to comply with the limits for a Class A digital device, pursuant to Part 15 of the FCC rules. While these devices are verified as Class A devices, they have been shown to meet the Class B limits. These limits are designed to provide reasonable protection against harmful interference when the equipment is operated in a commercial environment. This equipment generates, uses, and can radiate radio frequency energy and, if not installed and used in accordance with the instruction manual, may cause harmful interference to radio communications. Operation of the equipment in a residential area is likely to cause harmful interference in which case the user will be required to correct the interference at his own expense.

If necessary, the user should consult the dealer or an experienced radio and television technician for additional suggestions.

The user may find the booklet "How to Identify and Resolve Radio-TV Interference Problems" helpful. It is prepared by the Federal Communications Commission and is available from the U.S. Government Printing Office, Washington, DC 20402, Stock No. 004-000-00345-4.

2.2 Caster/Leg Installation

Depending upon the specific configuration ordered, your unit might have been shipped without installed casters or legs. If casters or legs are installed, you may skip this section and proceed to Section 2.3, Pre-Connection Preparations.

If your unit requires the installation of casters/legs, install them in accordance with the instructions included in your accessory package.

2.3 Pre-Connection Preparations

After the unit has been positioned in the area where it will be used, ensure the following have been accomplished before connecting the unit to the electrical power source:

1. This equipment must be stabilized by installing restraining chains on units equipped with casters or anchor straps on units equipped with legs. Follow the instructions shipped with the casters/legs to properly install the chains or straps.
2. Level units equipped with legs by screwing the legs out approximately 1 inch, then adjusting them so that the unit is level.

For units equipped with casters, there are no built-in leveling devices. The floor where the unit is to be installed must be level.

3. Install the basket lift arm (on units so equipped) on the lift rod (located at the top rear of the cabinet) so that the basket lift roller guides the lift arm.

NOTE: *Some adjustment of the roller may be necessary for free movement of the basket lift arm.*

4. Connect the water hose to the fitting at the rear of the unit. A new hose set should be used for the water connection and any old hoses discarded.

 **DANGER**

The maximum allowable incoming water pressure for all units is 80 PSI (5.6 kg/cm²)
(551.6 kPa).

The maximum allowable incoming water temperature for all units is 180°F (82°C).

NOTE: *Either hot or cold water may be connected to the unit. However, connecting hot water will minimize the time required to bring the unit to boil when filling with fresh water.*

NOTE: *In order for the water level sensors to work properly, a certain amount of mineral content is necessary in the water. For that reason, purified, deionized, or highly filtered water should not be used.*

5. Connect the desired drain plumbing to the drain valve.

2.4 Connecting to the Electrical Power Supply

 **DANGER**

This unit must be connected to the voltage and phase specified on the rating and serial number plate located on the inside of the equipment door. To determine the appropriate wire size, refer to the **POWER REQUIREMENTS** chart at the bottom of this page.

1. If the unit is not equipped with an installed power cord, open the door and remove the contactor box cover. Position the unit to gain access to the rear and remove the lower back panel.
2. Insert an appropriately rated power cord into the rear of the contactor box and make connections in accordance with the applicable wiring diagram on the following page. The supply cord must be oil resistant and not lighter than ordinary polychloroprene (60245 IEC 57). Install a strain relief on the power cord and replace the lower back panel and contactor box cover.
3. Attach a plug that complies with national and/or applicable local codes to the free end of the electrical power cord and plug the unit into an appropriate outlet.
4. The power plug is the disconnect device and the cord must be accessible when the unit is installed and operating.

POWER REQUIREMENTS				
Use copper wire ONLY, suitable for at least 170°F (75°C)				
Volts	Phase	Watts	Amps (per leg)	Minimum Wire Size
200	Single	7400	37	AWG 6 (4.1 mm)
208	Single	8000	39	AWG 6 (4.1 mm)
220	Single	7300	34	AWG 6 (4.1 mm)
230	Single	8000	35	AWG 6 (4.1 mm)
240	Single	8000	34	AWG 6 (4.1 mm)
200	3P – Delta	7400	22	AWG 8 (3.3 mm)
208	3P – Delta	8000	23	AWG 8 (3.3 mm)
220	3P – Delta	7300	20	AWG 8 (3.3 mm)
230	3P – Delta	8000	21	AWG 8 (3.3 mm)
240	3P – Delta	8000	20	AWG 8 (3.3 mm)
200	3P – Wye	7400	13	AWG 8 (3.3 mm)
220	3P – Wye	7300	12	AWG 8 (3.3 mm)
230	3P – Wye	7400	11	AWG 8 (3.3 mm)

NOTE: This equipment is field-convertible between single phase and three phase.

FIELD CONNECTION WIRING DIAGRAMS

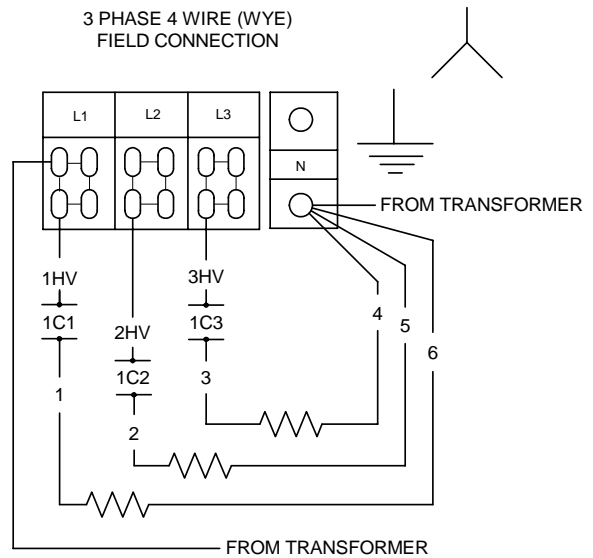
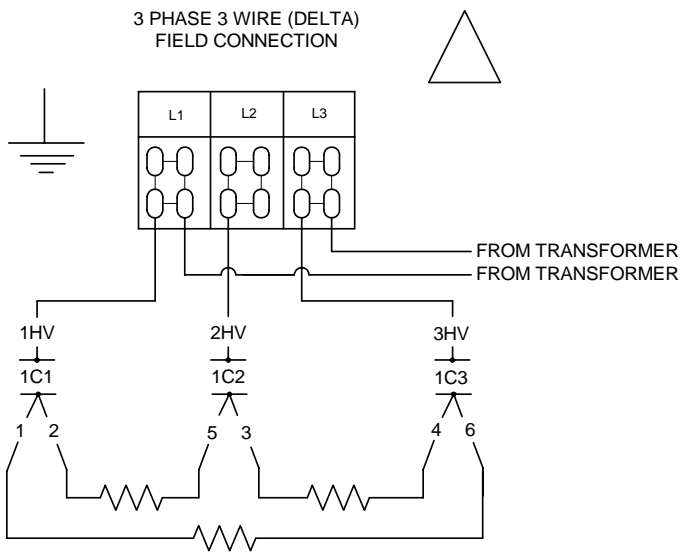
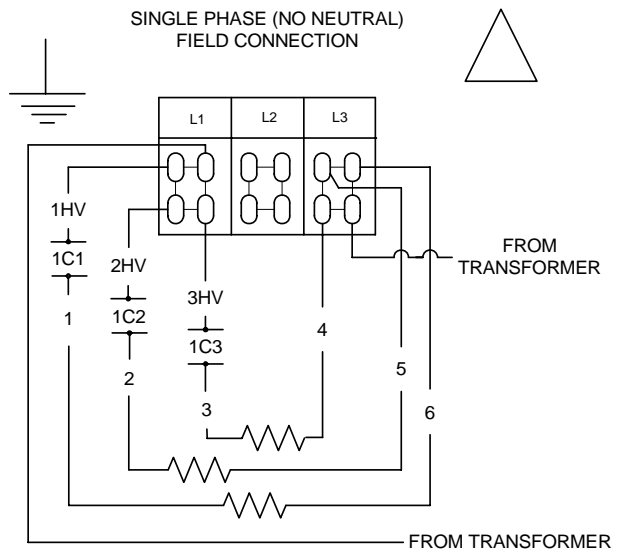
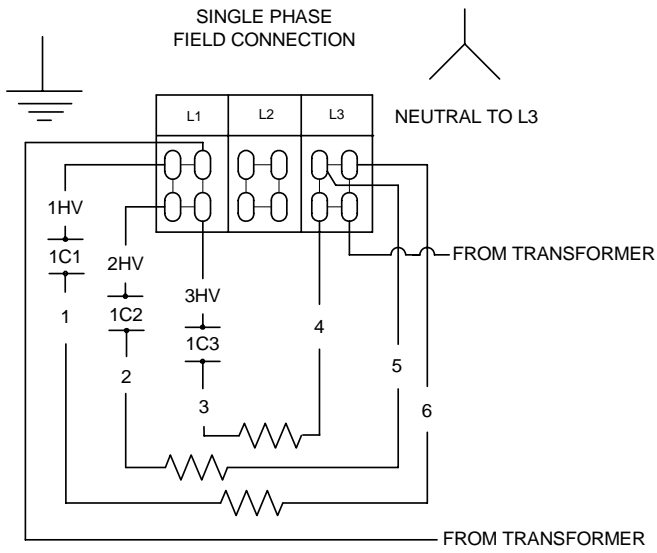

ELECTRIC COOKERS 8SMS, 8BC AND 8C

CHAPTER 3: OPERATING INSTRUCTIONS

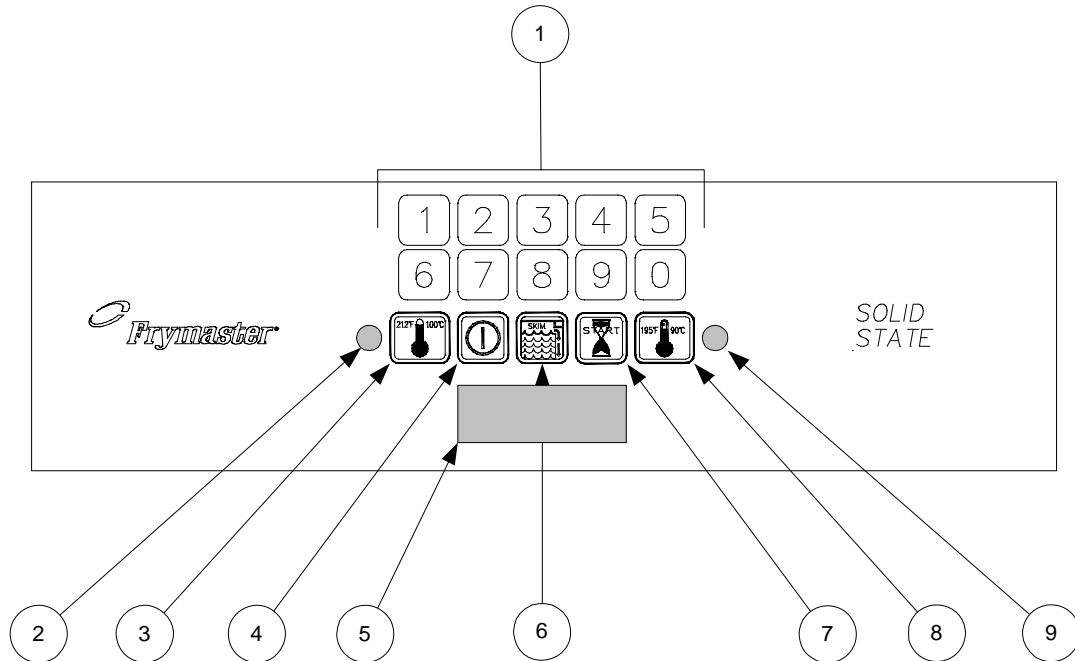

1	Numeric Keypad	6	Skim Switch (w/Autoskim only)
2	Boil Mode Indicator	7	Timer Start Switch
3	Boil Mode Switch	8	Simmer Mode Switch
4	Power Switch	9	Simmer Mode Indicator
5	LED Display		

3.1 Introduction

The Spaghetti Magic II Controller allows the operator to specify a specific cook time, in minutes and seconds, then initiate a cooking cycle. This controller is available in three different configurations. The standard configuration has both automatic filling (Autofill) and automatic skimming (Autoskim) features. Options include Autofill only, or neither Autofill or Autoskim. On units configured with the Autoskim feature, the operator may activate or deactivate the feature as desired.

When in the **BOIL** mode, the heating element is energized at all times. It is used when actually cooking pasta.

The **SIMMER** mode feature maintains the water temperature just below boiling, which conserves energy and water. This feature is designed for rethermalizing previously cooked packaged products, and for keeping the cooker in standby.

The **SKIM** feature, when selected, adds water for approximately 3 seconds once a minute. It causes the water to overflow into the drain, carrying floating starch with it. (A buildup of starch reduces the effi-

ciency of the cooker and can cause erroneous temperature and water level sensing. **NOTE:** Do not use deliming solution to clean these units. Use of deliming solution will damage all stainless steel parts.)

LOW WATER SENSING automatically de-energizes the heating element if the water in the cookpot drops too low. When the water level in the cookpot is below the low-water sensor, such as when draining and cleaning the cookpot, the controller display will read **LO**.

NORMAL WATER LEVEL SENSING, on units configured with the Autofill feature, automatically adds water during or after a cooking cycle if the water in the cookpot drops to a level lower than approximately 1¼ inch (32mm) below the overflow drain. With this automatic filling feature, the water level does not have to be continuously monitored. The cookpot always has the correct amount of water.





3.2 Operating Instructions

Before turning the cooker on, ensure that:

- the unit is connected to the water supply.
- the water supply is turned on.
- the unit is plugged into an appropriate outlet.
- the electrical power supply is turned on.
- only the vessels provided or recommended are used for cooking.

CAUTION

If this is the first time the unit is being used after installation, refer to Section 3.4, *Boiling Out the Cookpot*.

1. Turn the controller on by pressing the Power  switch.
2. The unit will automatically enter the boil mode and the boil mode indicator will illuminate. If you do not intend to immediately begin cooking, press the Simmer Mode  switch. The simmer mode indicator will illuminate. To re-enter the boil mode, press the Boil Mode  switch.
3. Enter the desired cooking time using the numeric keypad. The time entered appears in the LED display.
4. When ready to initiate a cooking cycle, press the Start Timer  switch. The basket lift will automatically lower the basket or portion cups into the cookpot and the LED display will begin to count down. At the end of the cooking cycle, an alarm will sound briefly to alert you and the basket lift will automatically raise the basket or portion cups out of the water.

The display will automatically return to the previously set cooking time. If the same time is desired for the next batch, simply press the Start Timer  switch when ready, otherwise enter the new cooking time before pressing the switch.

5. To initiate the automatic skimming (Autoskim) feature, press the Skim  switch.

3.3 Toggling Between Fahrenheit and Celsius Temperature Display

There are two versions of the SMS Controller: one that can be toggled between Fahrenheit and Celsius temperature display, and one that cannot. To determine which version you have, turn the controller off by pressing the ON/OFF switch. The display will go blank. Press the Simmer (right thermometer icon) switch. If *Code* appears in the display, the temperature display can be changed. If not, the display cannot be changed.

1. If *Code* appears in the display, press 1, 6, 5, 8. The display will be toggled from Fahrenheit to Celsius or from Celsius to Fahrenheit.
2. Press the Boil (left thermometer icon) switch to display the cookpot temperature. If an **F** follows the temperature, the display is in Fahrenheit; if a **C** follows the temperature, the display is in Celsius.

3.4 Shutting the Cooker Down

Turn the unit off by pressing the Power  switch. If shutting down at the end of the day, drain and clean the cookpot (and rinse tank, if so equipped), and put the cookpot and rinse tank covers in place.

3.5 Boiling Out the Cookpot

To ensure that the cooker is free of contamination from manufacture, shipping, or handling during installation, the cookpot must be boiled out before first use.

1. Close the drain valve and fill the cookpot with a solution of cold water and 1 cup of detergent.
2. Place the unit into operation (see Section 3.2).
3. Press the simmer switch  and allow the solution to simmer for at least 1 hour.
4. After the solution simmers for 1 hour, turn the unit off and add cold water until the solution is cool. Drain the solution and clean the cookpot thoroughly with a solution of dishwashing detergent and hot water.

NOTE: Do not use deliming solution to clean these units. Use of deliming solution will damage all stainless steel parts.

WARNING

When cleaning around the elements, be careful not to bend or otherwise damage the high-limit thermostat capillary tube.

5. Rinse the cookpot at least twice by filling with clean water and draining. Dry the cookpot thoroughly with a clean, dry towel.
6. For units equipped with a rinse tank, clean the tank with a solution of dishwashing detergent and hot water. Drain the tank and dry it thoroughly with a clean, dry towel.

ELECTRIC COOKERS 8SMS, 8BC AND 8C

CHAPTER 4: PREVENTIVE MAINTENANCE

4.1 Daily Preventive Maintenance

It is normal for a coating of starch to form on the elements, sensors, and temperature probes during operation. If the coating is allowed to build-up, it will adversely affect the operation of the equipment. The preventive maintenance routines below should be performed at least daily to keep your equipment functioning at peak efficiency. The cookpot and rinse tank – especially the water-level sensors, temperature probe, and element – may require more frequent cleaning, depending upon the product and volume. **NOTE:** Do not use deliming solution to clean these units. Use of deliming solution will damage all stainless steel parts.

Inspect Equipment and Accessories for Damage

Look for loose or frayed wires and cords, leaks, foreign material in cookpot or inside cabinet, and any other indications that the equipment and accessories are not ready for safe operation.

Clean Cabinet Inside and Out

Clean inside the cabinet with a dry, clean cloth. Wipe all accessible metal surfaces and components to remove accumulations of oil, dust, or cooking residue.

Clean the outside of the cabinet with a clean cloth dampened with dishwashing detergent, removing oil, dust, or cooking residue.



Never attempt to clean this equipment during the cooking process or when the cookpot is filled with hot water and/or food products.

Clean Water-Level Sensors, Temperature Probe, Element, Cookpot, and Rinse Tank

Turn the equipment off and drain the cookpot (and rinse tank, if so equipped).

Remove the probe cover and clean the water-level sensors and temperature probe using a Scotchbrite™ or similar abrasive pad and a solution of detergent and water.

Using a Scotchbrite™ or similar abrasive pad and a solution of detergent and water, clean the inside of the cookpot (and rinse tank, if so equipped). Pay particular attention to the heating element. Rinse the cookpot (and rinse tank, if so equipped) thoroughly with clean water at least twice.



Do not use deliming solution to clean these units. Use of deliming solution will damage all stainless steel parts.



When cleaning around the element, be careful not to bend or otherwise damage the high-limit thermostat capillary tube.

4.2 SMS II Controller Simmer Mode Adjustment

NOTE: The SMS II Controller simmer temperature is adjustable from 185°F to 215°F.

1. With the unit in the simmer mode, place the tip of a good grade thermometer near the temperature probe and determine the actual water temperature in degrees Fahrenheit. If the temperature is within 5°F of the desired simmer temperature, nothing more needs to be done. If it is not within 5°F of the desired temperature, perform Steps 2 through 5.
2. With the unit in the simmer mode, open the control panel by removing the screws in the upper corners and tilting the panel out.
3. Remove the black rubber plug from the top of the controller housing.
4. Using a small, flat-tipped screwdriver, turn the adjusting screw to change the simmer setpoint. ¼ turn will change the setpoint about 10°F. (You will have to experiment with the direction of rotation to determine which way to turn to raise or lower the temperature.) Wait at least 5 minutes, then recheck actual water temperature. Repeat this step until the water temperature is within 5°F of desired temperature.
5. Replace the plug in the controller, close the control panel, and replace the screws removed in Step 1.

ELECTRIC COOKERS 8SMS, 8BC AND 8C

CHAPTER 5: OPERATOR, TECHNICIAN TROUBLESHOOTING

5.1 Introduction

This chapter provides an easy reference guide to the more common problems that may occur during the operation of this equipment. The troubleshooting guides in this chapter are intended to help you correct, or at least accurately diagnose, problems with the equipment. Although the chapter covers the most common problems reported, you may very well encounter a problem not covered. In such instances, the Frymaster Technical Service Department will make every effort to help you identify and resolve the problem.

When troubleshooting a problem, always use a process of elimination starting with the simplest solution and working through to the most complex. Never overlook the obvious. Anyone can forget to plug a cord into a receptacle or open the valve on the water supply line. Don't assume that you are exempt from such occurrences. Most importantly, try to establish a clear idea of why a problem has occurred. Part of your corrective action involves taking steps to ensure that it doesn't happen again. If a controller malfunctions because of a poor connection, check all other connections while you're at it. If a fuse continues to blow, find out why. Keep in mind that failure of a small component may often be indicative of potential failure or incorrect functioning of a more important component or system.

Some of the troubleshooting actions recommended in this chapter involve removing suspect controllers and substituting controllers that are known to be good. This work should only be done by trained technicians. Whenever this is indicated, refer to Section 5.3. Refer to Section 5.4 for instructions on replacing fuses.

If you have doubts as to the proper action to take, do not hesitate to call the Frymaster Technical Service Department or your local Frymaster Factory Authorized Service Center for assistance.

Before calling a servicer or the Frymaster HOTLINE (1-800-551-8633):

- **Verify that electrical cords are plugged in and that circuit breakers are on.**
- **Verify that water supply valves are open and that drain valves are fully closed.**

 **DANGER**

Hot water can cause severe burns. Never attempt to move a cooker containing hot water or to transfer hot water from one container to another.

 **DANGER**

Use extreme care when performing electrical circuit tests. Live circuits will be exposed.

 **WARNING**

Inspection, testing, and repair of electrical components should be performed only by qualified service personnel. The equipment should be unplugged when servicing, except when electrical tests are required.

5.2 Operator Troubleshooting Guides

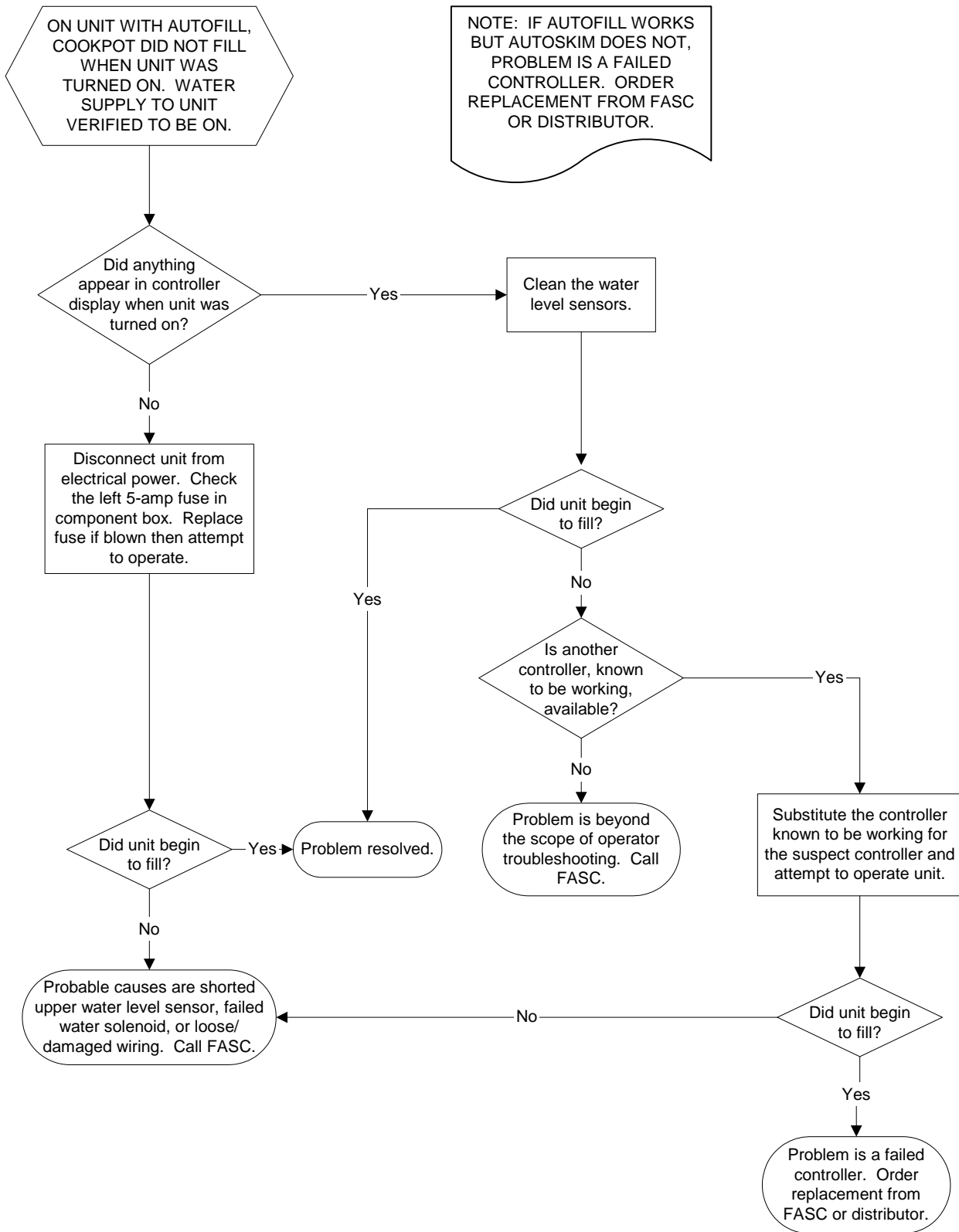

Operator Troubleshooting Guides (Continued)

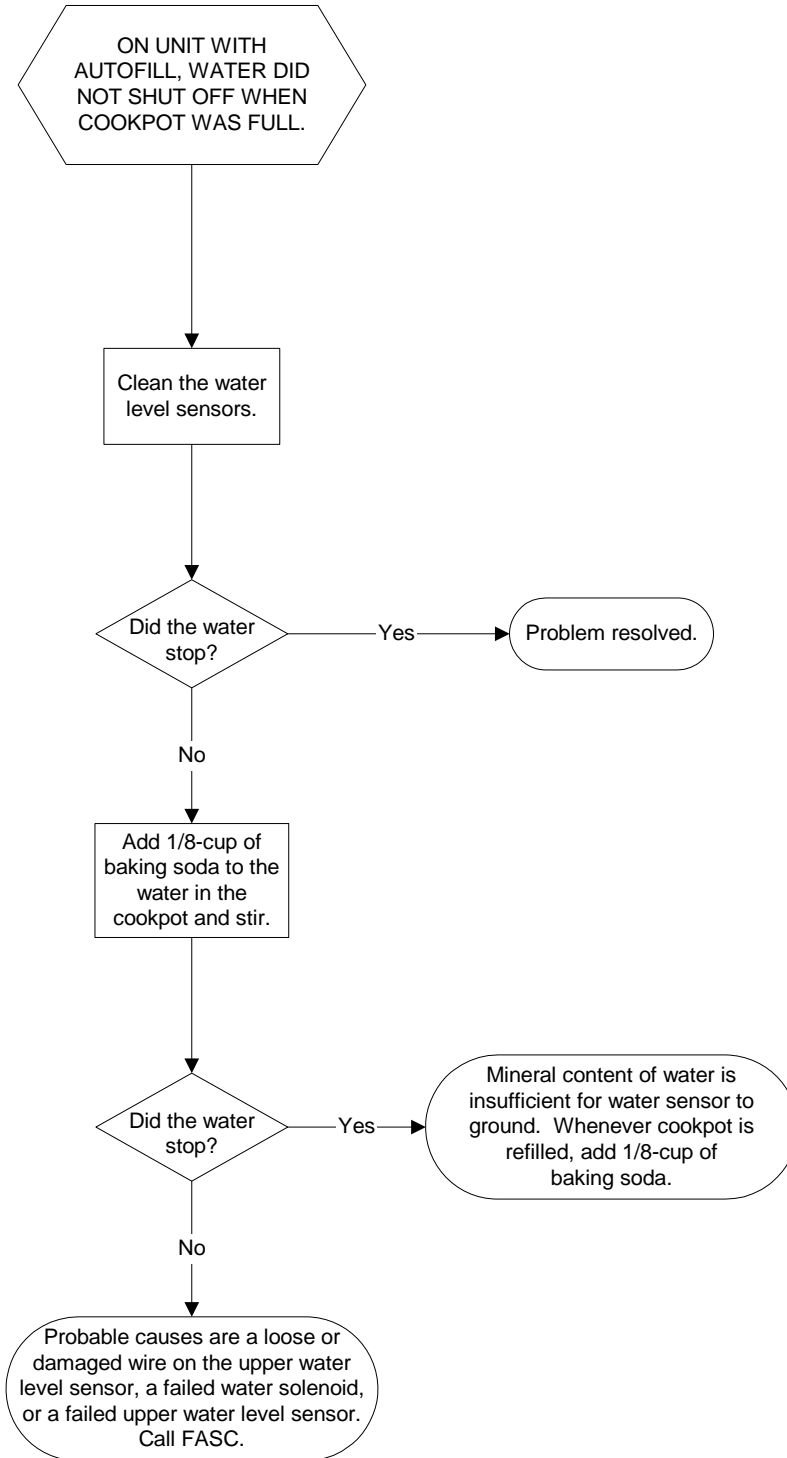

Operator Troubleshooting Guides (Continued)

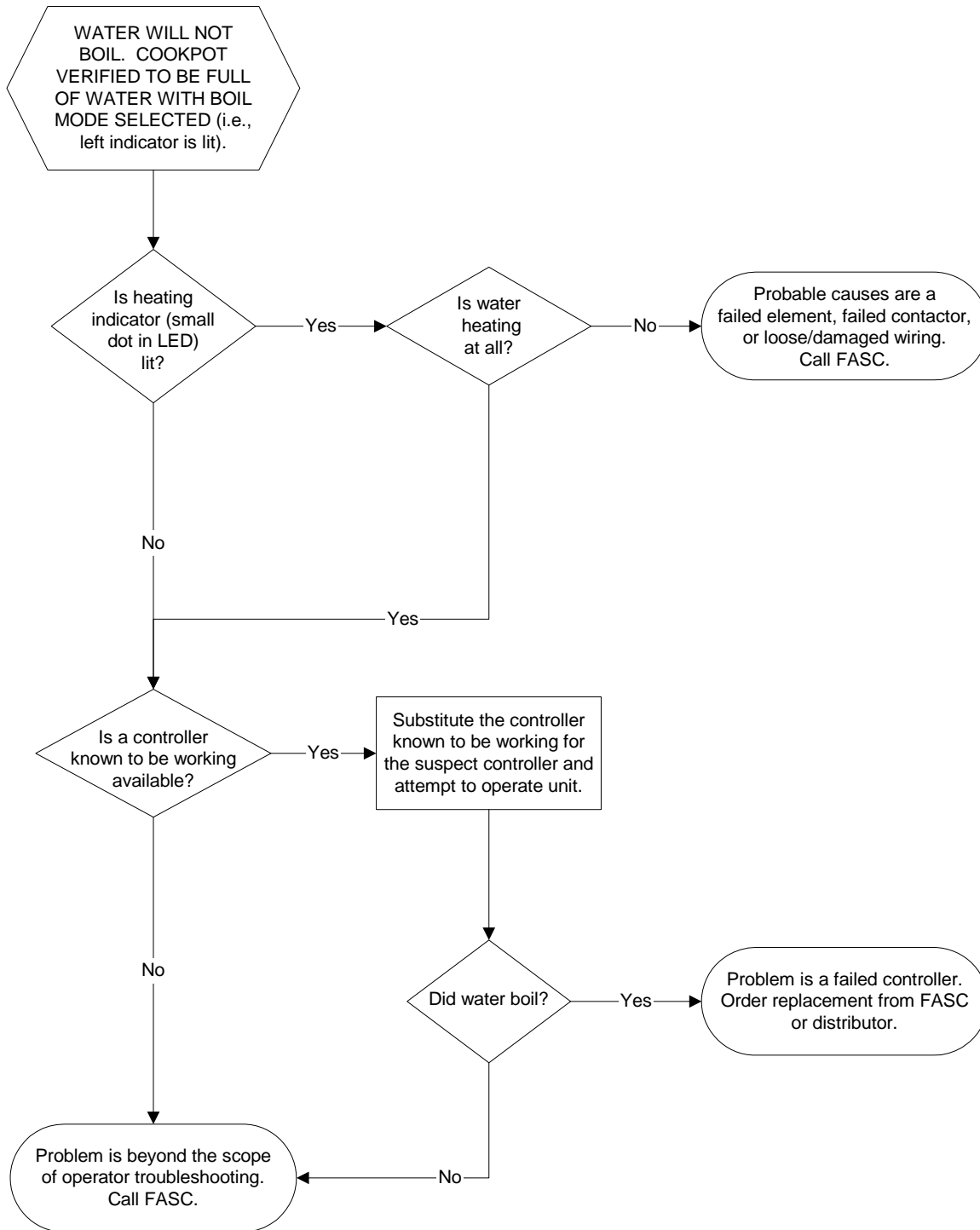

Operator Troubleshooting Guides (Continued)

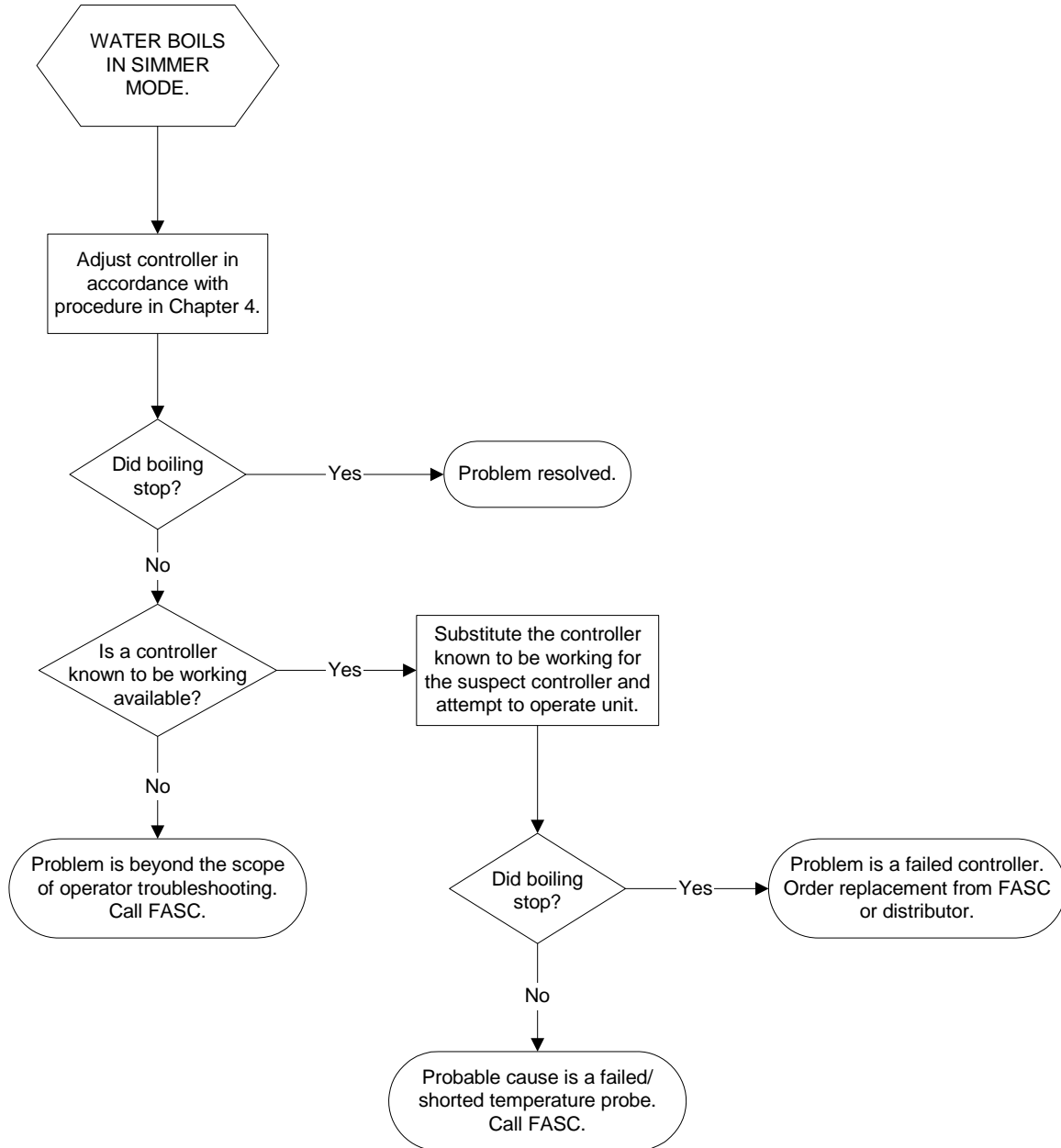

Operator Troubleshooting Guides (Continued)

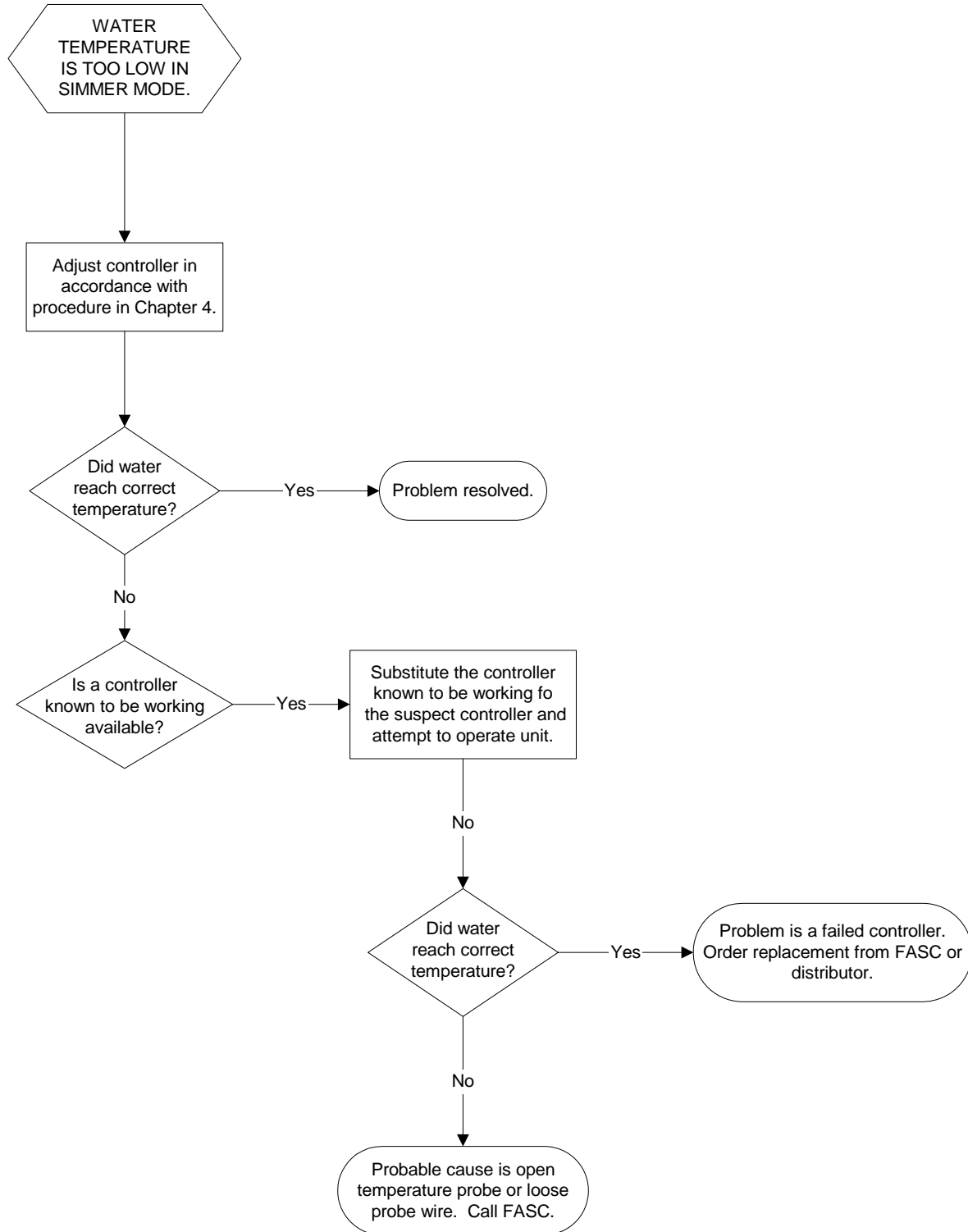

Operator Troubleshooting Guides (Continued)

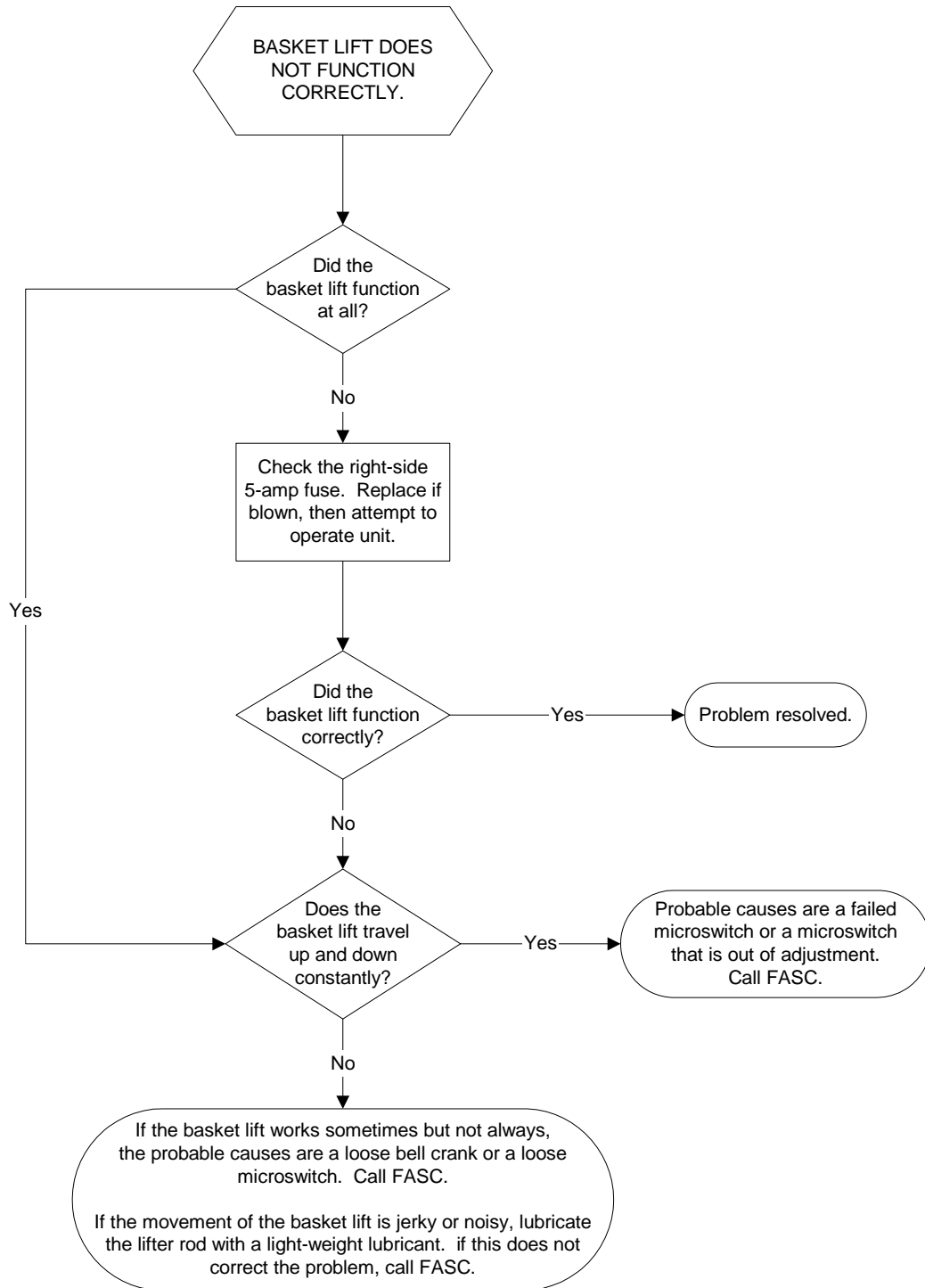

5.3 Replacing the Controller or Controller Wiring Harness

1. Disconnect the cooker from the electrical supply.
2. Remove the two screws in the upper corners of the control panel and swing the panel open from the top, allowing it to rest on its hinge tabs.
3. Disconnect the wiring harness from the back of the computer.
4. Disconnect the ground wire from the computer. Remove the controller by lifting it from the hinge slots in the frame.
5. Reverse the procedure to install a new computer or wiring harness.

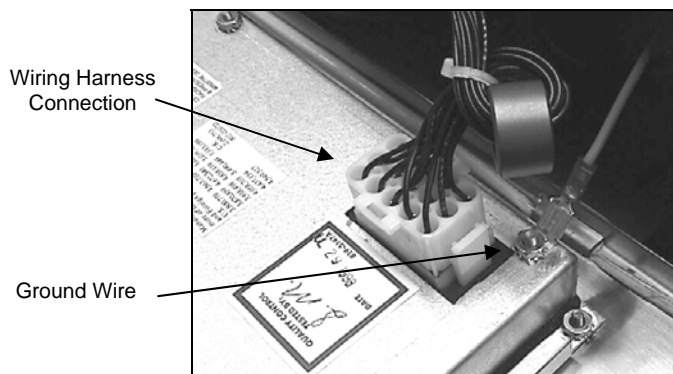

5.4 Replacing Fuses

1. Disconnect unit from electrical power and remove the cover from the contactor box located in the left front bottom of the cabinet.
2. The 5-amp fuse for the controller is located on the left side of the box. The 5-amp fuse for the basket lift is located on the right side of the box. Use a fuse puller to remove the blown fuse and install the replacement.

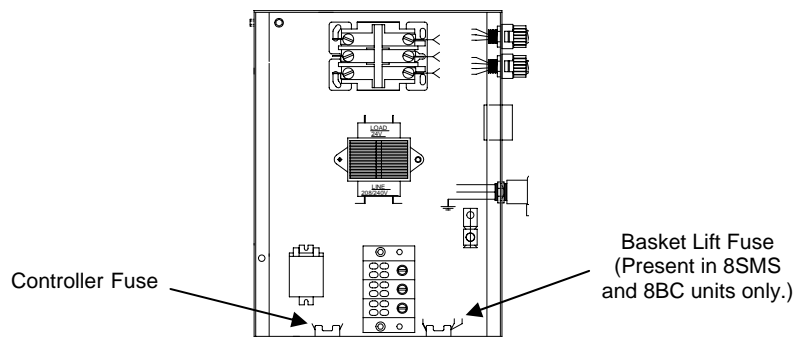

3. Replace the component box cover, being sure to reconnect the ground wire with the upper left screw.

ELECTRIC COOKERS 8SMS, 8BC AND 8C

CHAPTER 6: SERVICE PROCEDURES

6.1 Functional Description of Electric Cookers 8SMS, 8BC and 8C

Electric Cookers 8SMS, 8BC, and 8C contain an extruded stainless steel cookpot that holds 8.7 gallons (33 liters) of water. The water in the cookpot is heated by an 8-kilowatt element at the bottom of the pot. The solid-state SMS II Spaghetti Magic controller controls electrical power to the element. The 8SMS also has an 8.7 gallon (33 liter) rinse tank.

On units without the Autofill (automatic filling) option, when the controller is turned on by pressing the Power switch, logic circuits in the controller check for water in the cookpot by looking for a grounded low-water level sensor. (The sensor is grounded by contact with the water in the cookpot.) If the sensor is grounded, the controller automatically enters the BOIL mode, supplying continuous power to the element. If the operator selects the SIMMER mode, logic circuits in the controller monitor the temperature of the water and cycle power to the element on and off to maintain the temperature at the simmer mode setpoint. (See Section 4.2 in Chapter 4 for instructions for adjusting the simmer mode setpoint.) The cooker also has a high-limit safety. If the water in the cookpot falls below the low-water level sensor but the sensor remains grounded for whatever reason, the high-limit switch will open, cutting off power to the element, when the element temperature reaches $400 \pm 15^{\circ}\text{F}$.

On units equipped with the Autofill option, a logic circuit in the controller automatically opens a solenoid valve on the water supply line if the upper water level sensor is not grounded by contact with the water in the cookpot. When the Power switch is pressed, if the water level is below the upper water level sensor, water is automatically added to the cookpot. When sufficient water has been added to cover the heating element, the unit automatically enters the BOIL mode and remains there unless the operator presses the SIMMER mode switch or turns the unit off. When the water level in the cookpot contacts the upper water level sensor, the solenoid valve in the water supply line closes.

On units equipped with the Autoskim (automatic skimming) option, when the Skim switch is pressed, a logic circuit in the controller automatically opens the solenoid valve in the water supply line for three seconds every minute until the option is turned off by again pressing the Skim switch.

The operator enters a specified cooking time by pressing the number pads on the controller. When the Start switch is pressed, the controller begins to count down to zero. When the controller times out, an alarm sounds briefly, then the timer reverts to the last time entered.

On units equipped with basket lifts (8SMS or 8BC), when the Start switch is pressed to start the cooking cycle, logic circuits in the controller activate the basket lift motor, lowering the baskets into the cookpot. As the motor drives the basket lift down, a roller-activated switch loses contact with the bellcrank (cam) attached to the motor and power to the motor is cut. When the controller times out, logic circuits reverse the switch positions so that the motor circuit is again completed and the motor is restarted, raising the baskets from the cookpot. At the fully raised position, the roller switch again makes contact with the cam, cutting power to the motor and stopping the lift in the up position.

6.2 Accessing Equipment for Servicing

DANGER

Moving this equipment while it is filled with hot water may cause spilling or splattering of the hot water. Always drain the cookpot before attempting to relocate this equipment for servicing.

1. Disconnect the unit from the electrical power supply and from the water supply.
2. Remove any attached restraining devices.
3. Relocate the unit for service accessibility.
4. After servicing is complete, reconnect the unit to the water supply, reattach restraining devices, and reconnect the unit to the electrical power supply.

6.3 Replacing Equipment Components

6.3.1 Replacing the Controller

See Section 5.4.

6.3.2 Replacing the Transformer, Basket Lift Relay, Contactor, or Solenoid Valve

1. Drain the cookpot and disconnect the cooker from the electrical power supply.
2. Remove the cover from the component box. (It may be helpful to remove the drain plumbing below the drain valve to better access the interior of the component box.)
3. On the component to be replaced, make a note of the wiring connection points.
4. Disconnect the wires and remove the failed component (see illustration on next page). Install the replacement component and reconnect the wiring in accordance with the notes made in Step 3 or with the wiring diagram on the door of the unit.
5. Replace the component box cover, being sure to reconnect the ground wire. Replace any drain plumbing components that were removed and reconnect the cooker to the electrical power supply.

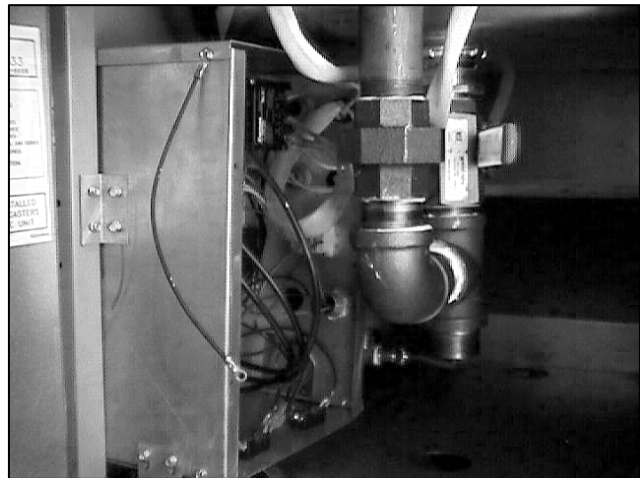

NOTE: This is a composite drawing for illustrative purposes only. It shows all parts that may be mounted in the component box. Depending upon the specific configuration of a particular unit, the actual parts present will vary.

NOTE: Refer to the following wiring diagrams for wiring connections:
 8050377J: 208V through 230V 8SMS, 8BC, 8C
 8050462C: 480V/120V 8SMS, 8BC, 8C

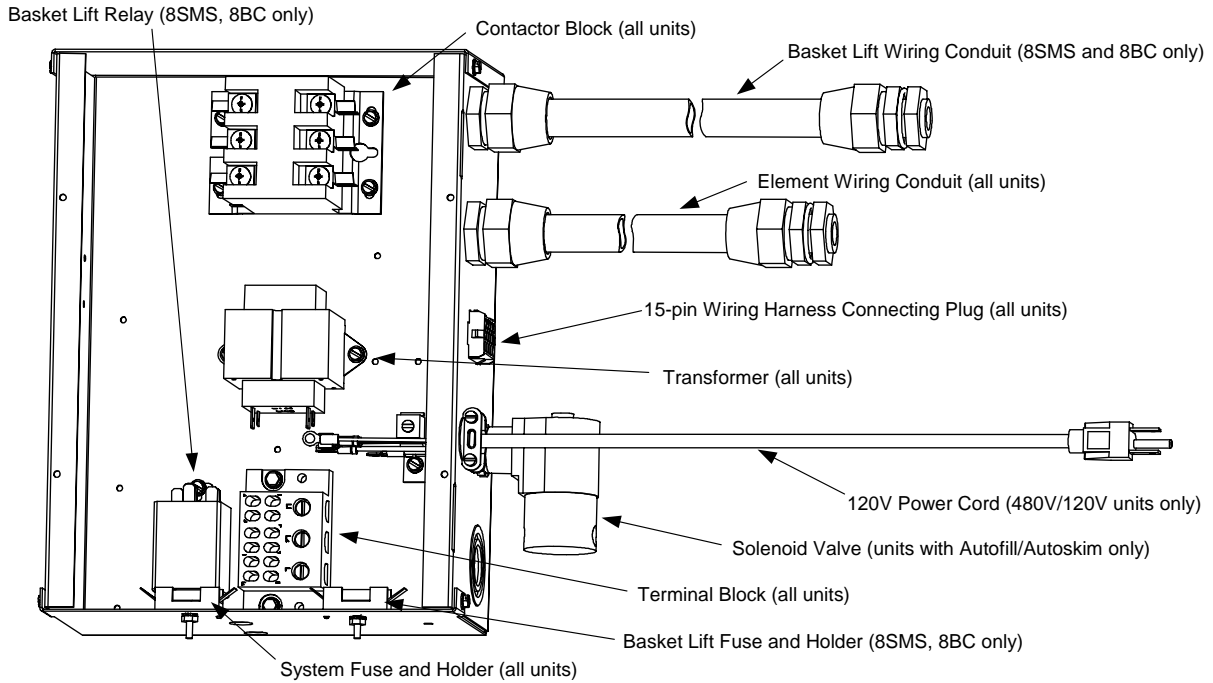

6.3.3 Replacing the Element

1. Drain the cookpot and disconnect the cooker from the electrical power supply.
2. Remove the cover from the component box. (It may be helpful to remove the drain plumbing below the drain valve to better access the interior of the component box.)
3. Make a note of where the leads are connected to the contactor block, then disconnect the leads.
4. Cut the wire ties on the fiberglass insulation and remove the insulation from the element leads.
5. Cut the metal wire ties that secure the high-limit thermostat to the element, being careful not to bend the thermostat.
6. Remove the brass nuts from the element legs and carefully pull the failed element from the cookpot.

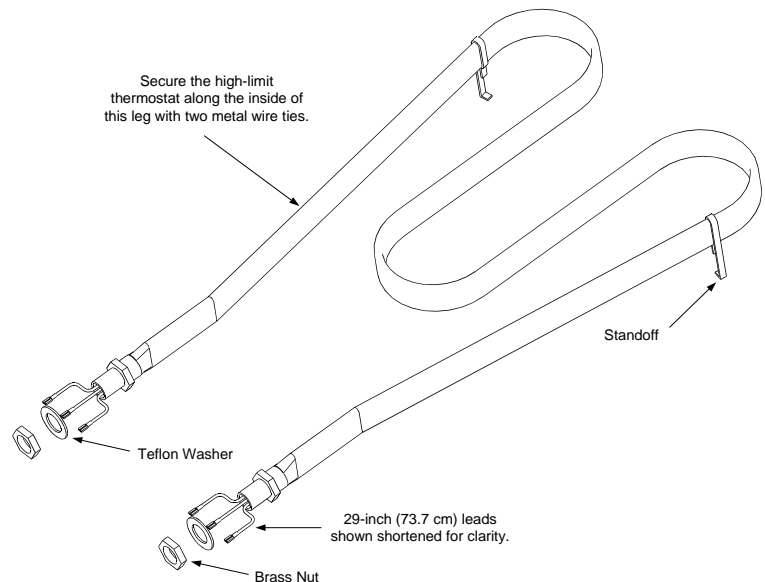

7. Position the replacement element in the cookpot with the standoffs on the bottom of the cookpot, and thread the element leads through the Teflon washers recovered from the failed element. Secure the element in place with the nuts removed in Step 5.
8. Install two metal wire ties to secure the high-limit thermostat against the inside of the left leg of the element.
9. Thread each set of element leads through the fiberglass insulation removed in Step 4 and secure the insulation in place with a wire tie as close as possible to the brass nut.
10. Thread one set of leads into the component box and connect them to the contactor block in accordance with the notes made in Step 3 or the wiring diagram on the door. **NOTE:** The leads are numbered to facilitate making proper connections. Repeat this step for the remaining set of leads.
11. Replace the cover on the component box, being sure to reconnect the ground wire. Reinstall any drain plumbing components that were removed, and reconnect the unit to the electrical power supply.

6.3.4 Replacing the High-Limit Thermostat

1. Drain the cookpot and disconnect the cooker from the electrical power supply.
2. Cut the metal wire ties securing the thermostat body to the element.
3. Open the control panel by removing the screws in each upper corner. Mark and then disconnect the two leads connected to the thermostat terminals.

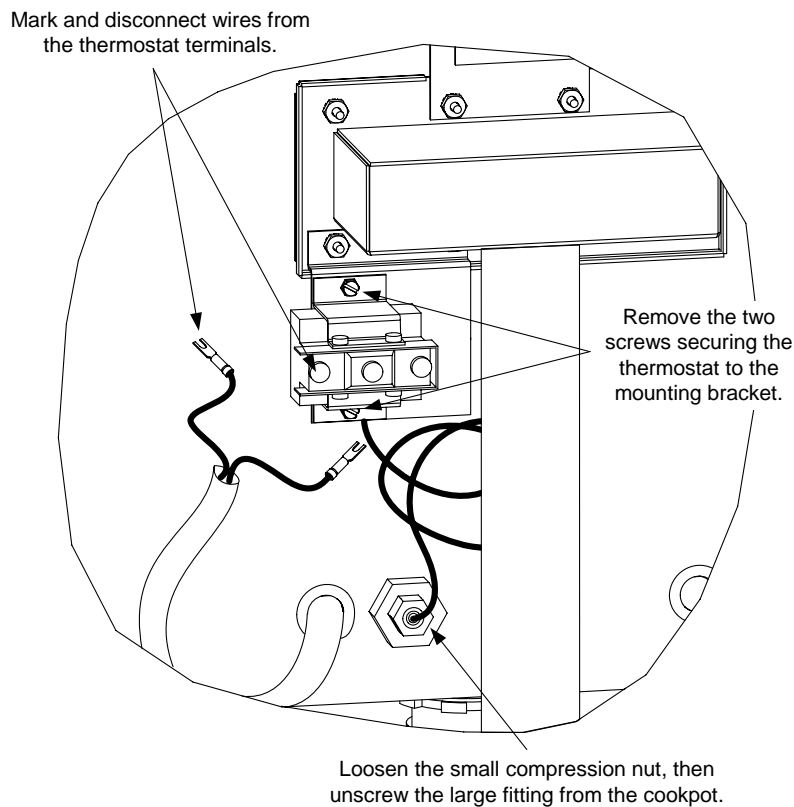

4. Loosen the small compression nut, then unscrew the large fitting from the cookpot.
5. Remove the two screws securing the thermostat to the mounting bracket. (**NOTE:** It is not necessary to remove the bracket.) Pull the thermostat from the cookpot.
6. Carefully insert the replacement thermostat into the cookpot, being careful not to bend the shaft.
7. Position the thermostat along the inside of the left leg of the element and secure it in place with two metal wire ties.
8. Unscrew the small compression nut from the large fitting on the replacement thermostat. Apply thread sealer to the large fitting and screw the fitting securely into the cookpot. When the large fitting is tight, screw the small compression nut into the large fitting and tighten.
9. Coil the thermostat capillary tube as necessary to achieve a neat installation and attach the terminal block to the mounting bracket using the screws removed in Step 5.
10. Reattach the leads disconnected in Step 3, being sure to reconnect them in accordance with the wiring diagram on the door of the unit or the markings made when they were disconnected.
11. Return the control panel to the closed position and secure in place with the screws removed in Step 3.
12. Reconnect the unit to the electrical power supply.

6.3.5 Replacing a Water Level Sensor or the Temperature Probe

1. Drain the cookpot and disconnect the cooker from the electrical power supply.
2. Remove the basket lift arm by lifting it straight up from the lifter rod. Remove the probe cover by lifting it straight up from the probe block.
3. At the rear of the unit, remove the two screws securing the access panel and remove the panel.

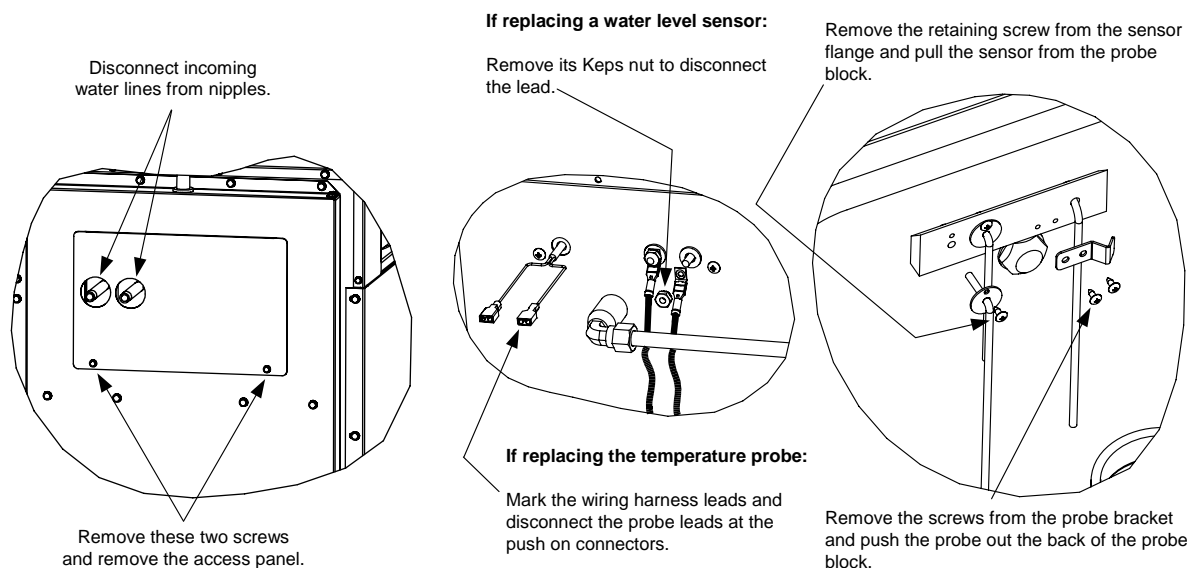

4. If replacing a water level sensor:
 - a. Disconnect the lead by removing the keps nut holding it in place.
 - b. Remove the screw in the sensor flange.
 - c. Carefully pull the failed sensor from the probe block and replace with the new sensor.
 - d. Reattach the lead and reverse Steps 1-3 to complete the procedure.

5. If replacing the probe:
 - a. Mark the wiring harness leads and disconnect them from the probe leads at the push-on connectors.
 - b. Remove the two screws in the probe bracket.
 - c. Carefully pull the probe from the probe block and replace with the new probe.
 - d. Reattach the leads and reverse Steps 1-3 to complete the procedure.

6.3.6 Replacing the Pressure Regulator

1. Drain the cookpot and disconnect the cooker from the electrical power supply.
2. Turn off or disconnect the water supply to the cooker. Disconnect the incoming water line where it connects to the cooker.
3. At the rear of the unit, remove the two screws securing the access panel in place and pull it back over the water lines sufficiently to allow access to the connections inside.

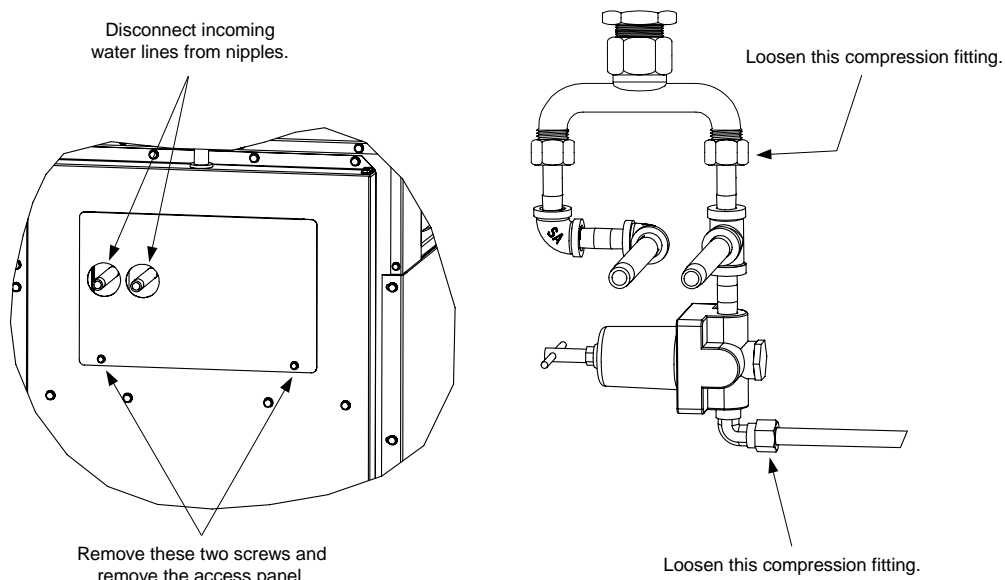

4. At the regulator, loosen the compression fitting on the water line to the solenoid valve. Loosen the compression fitting at the faucet inlet manifold. Remove the regulator from the unit.
5. Recover the fittings from the failed regulator and install them on the replacement using thread sealer on all connections.
6. Reverse Steps 1-4 to reinstall the regulator, being sure to apply thread sealer to all connections.
7. Adjust the regulator to not more than 40 PSI (2.8 Kg/cm²) (275.79 kPa).

6.3.7 Replacing the Water Faucet

1. Drain the cookpot and disconnect the cooker from the electrical power supply.
2. Turn off the water supply to the cooker.
3. Disconnect the incoming water lines at the nipples that protrude from the holes in the upper access panel. If necessary, remove any quick-disconnect fittings that would prevent the access panel from being removed. Remove the two screws securing the access panel in place and remove the panel (see illustration above).
4. If the cooker is equipped with a pressure regulator, disconnect the regulator by loosening the compression fitting on the outlet side (see illustration in Section 6.3.6 above).
5. Remove the screws from the faucet mounting plate and lift the entire faucet assembly from the unit.

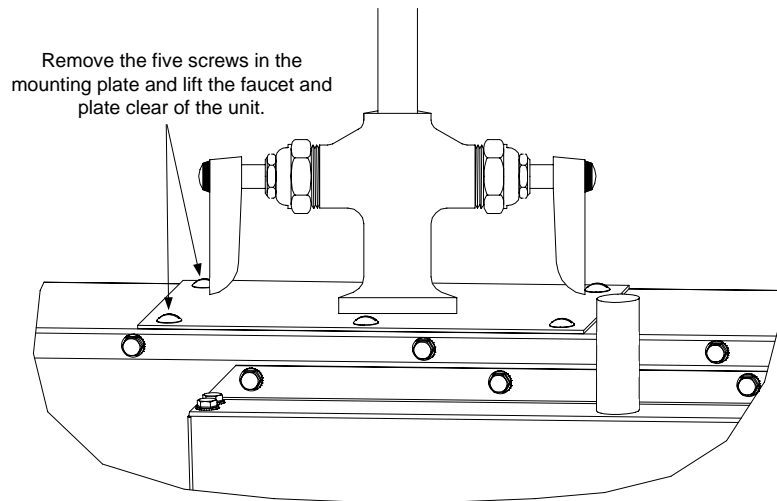

6. Separate the faucet manifold from the remainder of the plumbing as shown in the illustration below.

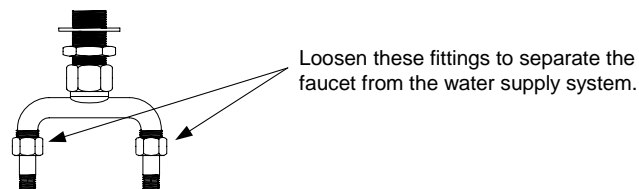

7. Disassemble the faucet from the mounting plate by removing the jamb nut and washer.

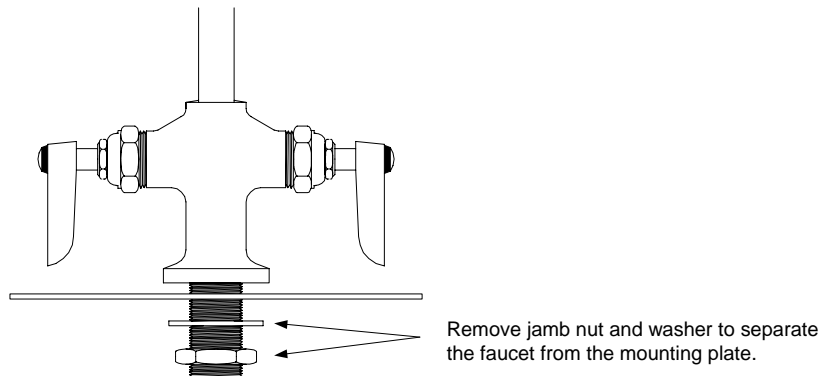

- Assemble the replacement faucet to the mounting bracket and complete the procedure by reversing Steps 1-6.

6.3.8 Replacing the Cookpot or Rinse Tank

- Disconnect the unit from the electrical power supply and from the water supply.
- Remove the cover from the component box, mark the element leads, disconnect them from the contactors, and pull them out of the component box.
- Remove the top cap to expose the pot hold-down bracket assembly. Remove the two Keps nuts attaching the assembly to the cookpot or rinse tank. Loosen but do not remove the screws in the top of the bracket. Remove the two screws attaching the bracket to the cabinet frame and remove the bracket assembly from the unit. On units with a rinse tank, remove the screw securing the connecting strip.

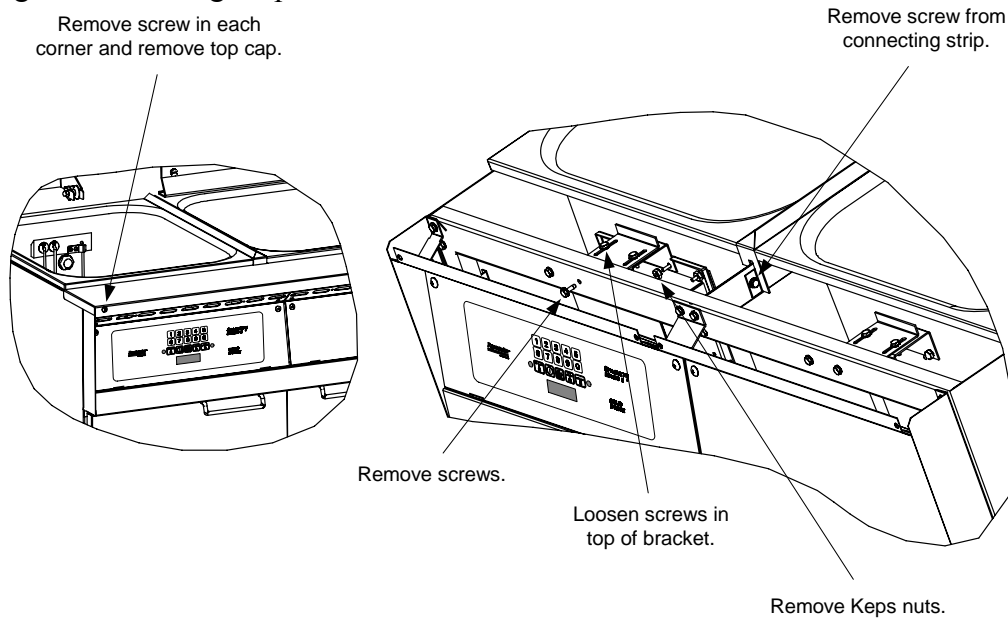

- At the rear of the unit, disconnect the incoming water lines (and any attached quick-disconnect fittings) from the nipples protruding from the upper access panel. Remove the panel and disconnect the water level sensor and temperature probe leads. If the cooker is equipped with the Autofill feature, disconnect the Autofill water line at the frypot end.

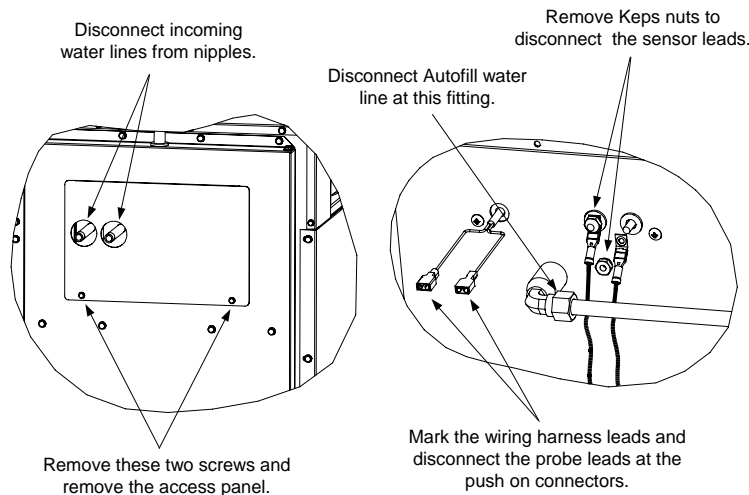

5. If the unit is equipped with a pressure regulator, disconnect the regulator from the water line at the outlet side.

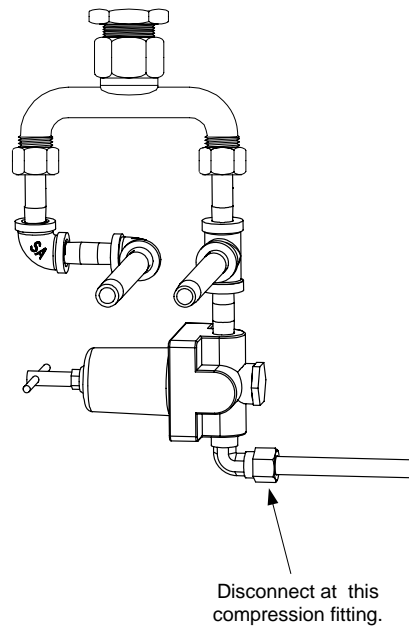

6. Remove the screws securing the fluecap assembly to the back panel of the cabinet and remove the assembly from the unit. On 8SMS units, remove the connecting strip disconnected in Step 4.

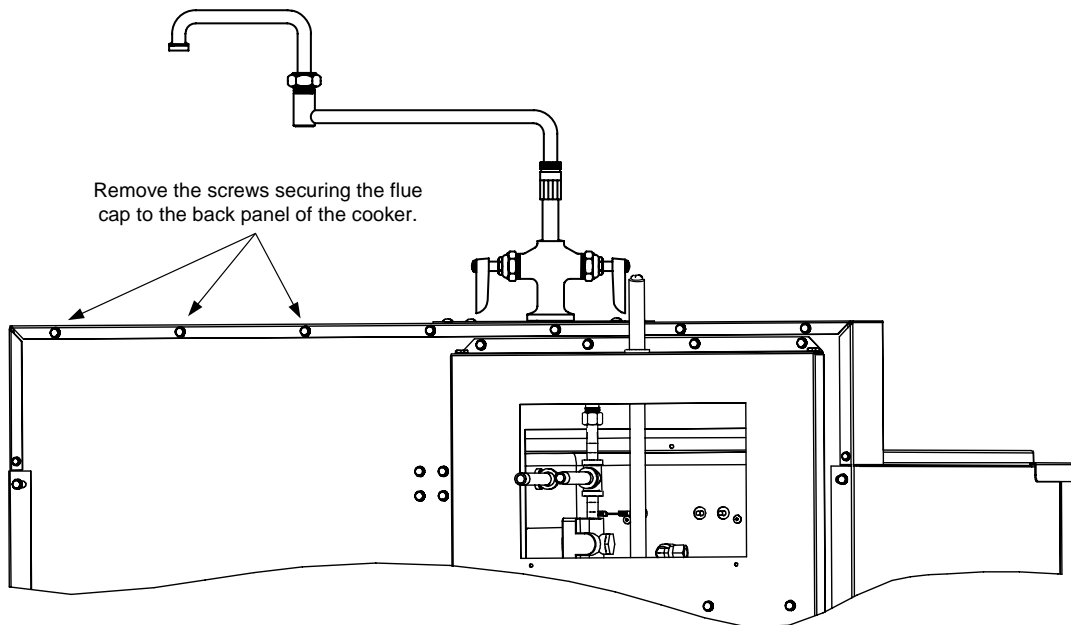

7. Using an assistant, lift the cookpot or rinse tank up and out of the cabinet.
8. Recover the components from the failed cookpot or rinse tank and install on the replacement cookpot or rinse tank.
9. Reverse steps 1 through 10 to complete the procedure.

6.3.9 Replacing the Basket Lift Motor and Related Components

1. Disconnect the unit from the electrical power supply and dismount the basket lift arm. Attach a pair of Vise Grip™ pliers (or a similar locking device) to the basket lift rod where it protrudes from the cabinet to prevent it from slipping back down into the cabinet when the basket lift link is disconnected from the bellcrank.
2. Remove the lower basket lift access panel.
3. Mark and disconnect the wires attached to the microswitch. Disconnect the white motor wire at the inline connector. Cut wire tie, if present, and carefully push all wires back into the cabinet through the holes in the motor mount.

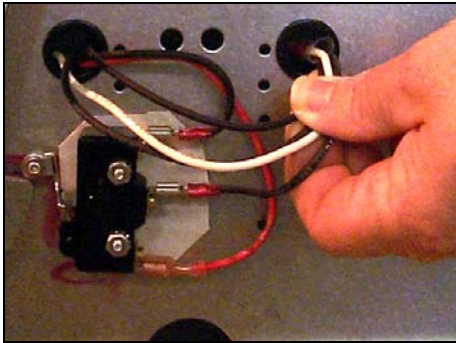

4. Remove the four slot-head screws that secure the motor mount assembly into the cabinet.
5. Disconnect the basket lift link from the bellcrank and remove the motor mount assembly from the cabinet.
6. Remove the failed component as shown in the illustration below and install the replacement component.

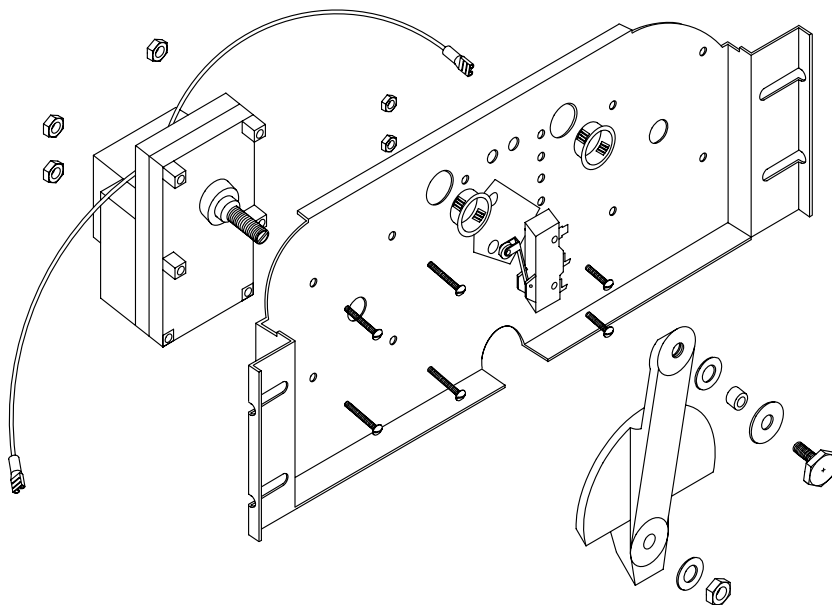

7. Complete the procedure by reversing steps 1-5.

6.4 Troubleshooting

6.4.1 How the Autofill System Works

The heart of the automatic filling (AutoFill) system is a normally closed solenoid valve that opens when 24VAC is applied. When the controller is turned on, it checks to see if the upper water level sensor is grounded by contact with water in the cookpot. If it is not, circuitry in the controller forms a ground for the 24VAC supplied to the solenoid, allowing the valve to open. When the water level in the cookpot reaches the upper water level sensor, the sensor is grounded, causing the controller to break the solenoid ground, thus shutting off the inflow of water.

Starch or lime build-up on the upper water level sensor may keep the ground from forming, therefore the sensor must be kept clean and its lead firmly connected. **NOTE:** Do not use deliming solution to clean these units. Use of deliming solution will damage all stainless steel parts.

This unit will not operate with distilled water. Pure water is non-conductive, so the required ground cannot be formed. If highly filtered or purified water is used, adding 1/8-cup of baking soda to the water will usually provide sufficient mineral content for the ground to form.

NOTE: In units equipped with the AutoSkim feature, when the skim switch on the controller is pressed, a logic circuit in the controller automatically interrupts the 24VAC ground for three seconds every minute until the switch is again pressed. Therefore, failure of the AutoSkim feature will be due to a malfunctioning controller and not the solenoid valve.

6.4.2 How the Water Heating System Works

To prevent energizing the heating elements when there is no water in the cookpot, these units are equipped with a **low-water level sensor** that must be grounded by contact with the water in the cookpot before the control circuitry will apply power to the elements.

Starch or lime build-up on the low-water level sensor may keep the ground from forming, therefore always make sure the sensor is clean and its lead is firmly connected. **NOTE:** Do not use deliming solution to clean these units. Use of deliming solution will damage all stainless steel parts.

The units will not operate with distilled water since pure water is non-conductive. In order for the ground to form, there must be some mineral content in the water. If highly filtered or purified water is used, add 1/8-cup of baking soda to the water each time the cookpot is emptied and refilled.

In addition to the low-water level sensor discussed above, the water heating system has five more parts: the high-limit thermostat, the temperature probe, the contactor block, the element, and the controller.

The **high-limit thermostat** functions as a normally closed switch. If the water in the cookpot falls below the low-water level sensor but the sensor remains grounded for whatever reason, the high-limit switch will open when the element temperature reaches 400°F ±15 (204°C ± 9), cutting off power to the contactor coil and thus to the element.

The **temperature probe** is used only when the unit is in the simmer mode. When the operator selects the simmer mode, logic circuits in the controller monitor the temperature of the water and cycle power to the element on and off to maintain the temperature at the setpoint programmed into the controller.

The **contactor block** is the terminal block to which the element leads are connected and where actual contact is made between the leads and the line voltage. Built into the contactor block is a coil (electronic switch) that closes when a ground for the 24VAC from the transformer is supplied by the controller calling for heat. When it closes, contact is made between the incoming line voltage and the element leads.

The **element** is a resistive heating device. That is, when voltage is applied to the element, the element gets very hot due to its resistance to current flow through it. The heat generated is transferred directly to the water in which the element is immersed.

The **controller** is the interface between the operator and the other components of the equipment. In the water heating system, its function is to control the application of line voltage to the heating element via the contactor coil.

Troubleshooting the water heating system consists of checking the above components for proper operation, as detailed in the troubleshooting diagrams on the next page.

6.4.3 Technician Troubleshooting Guides

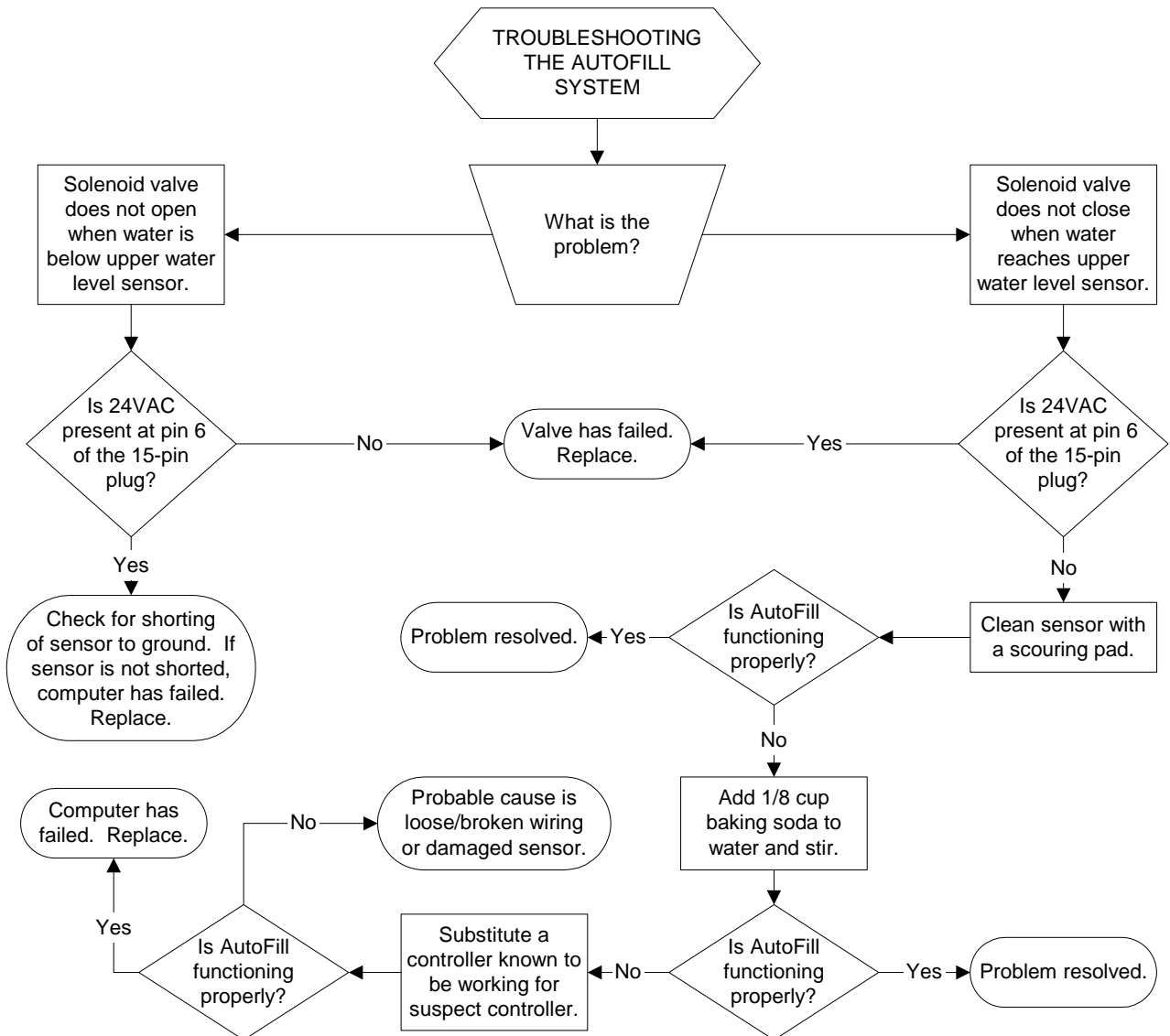

Technician Troubleshooting Guides (Continued)

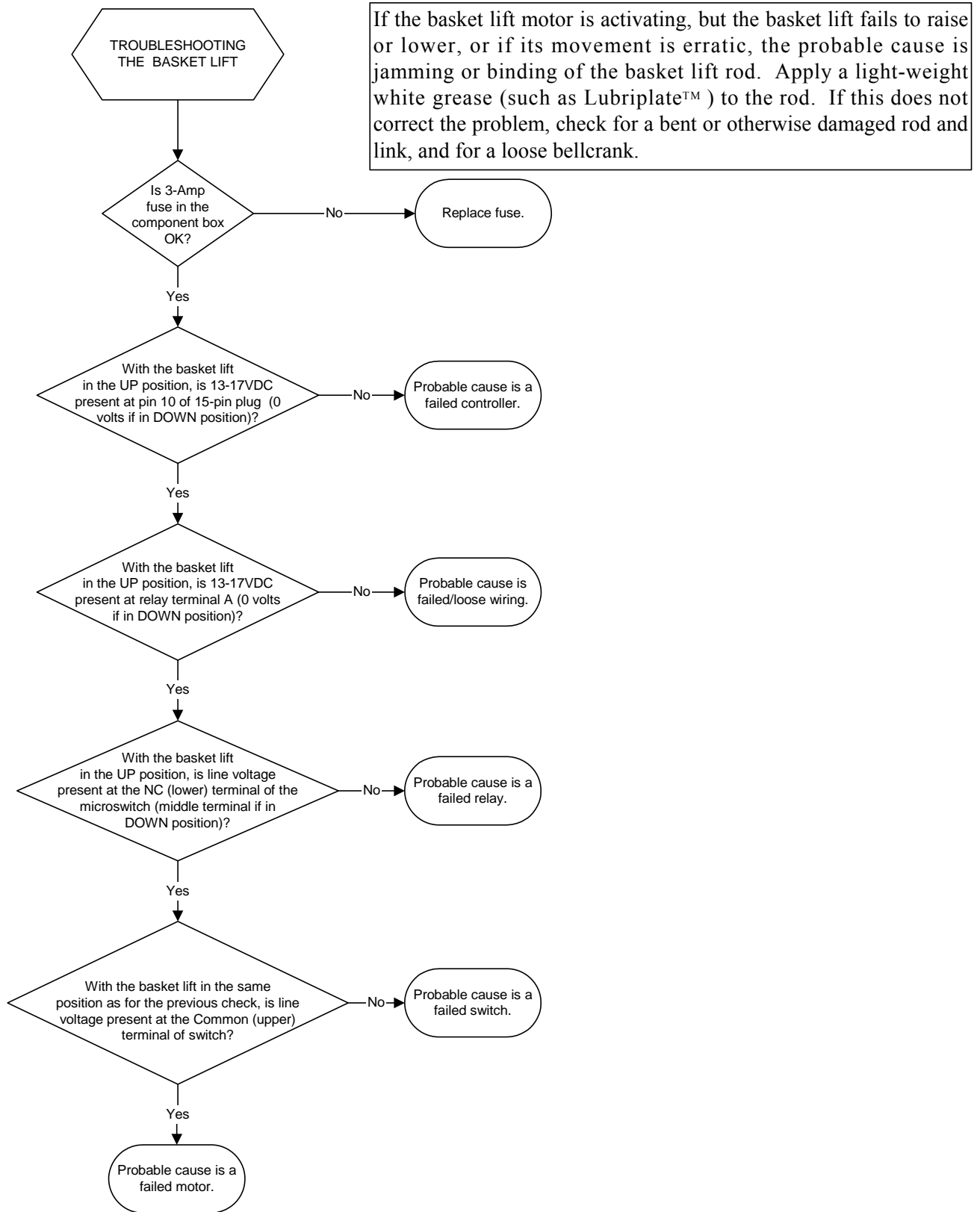

Technician Troubleshooting Guides (Continued)

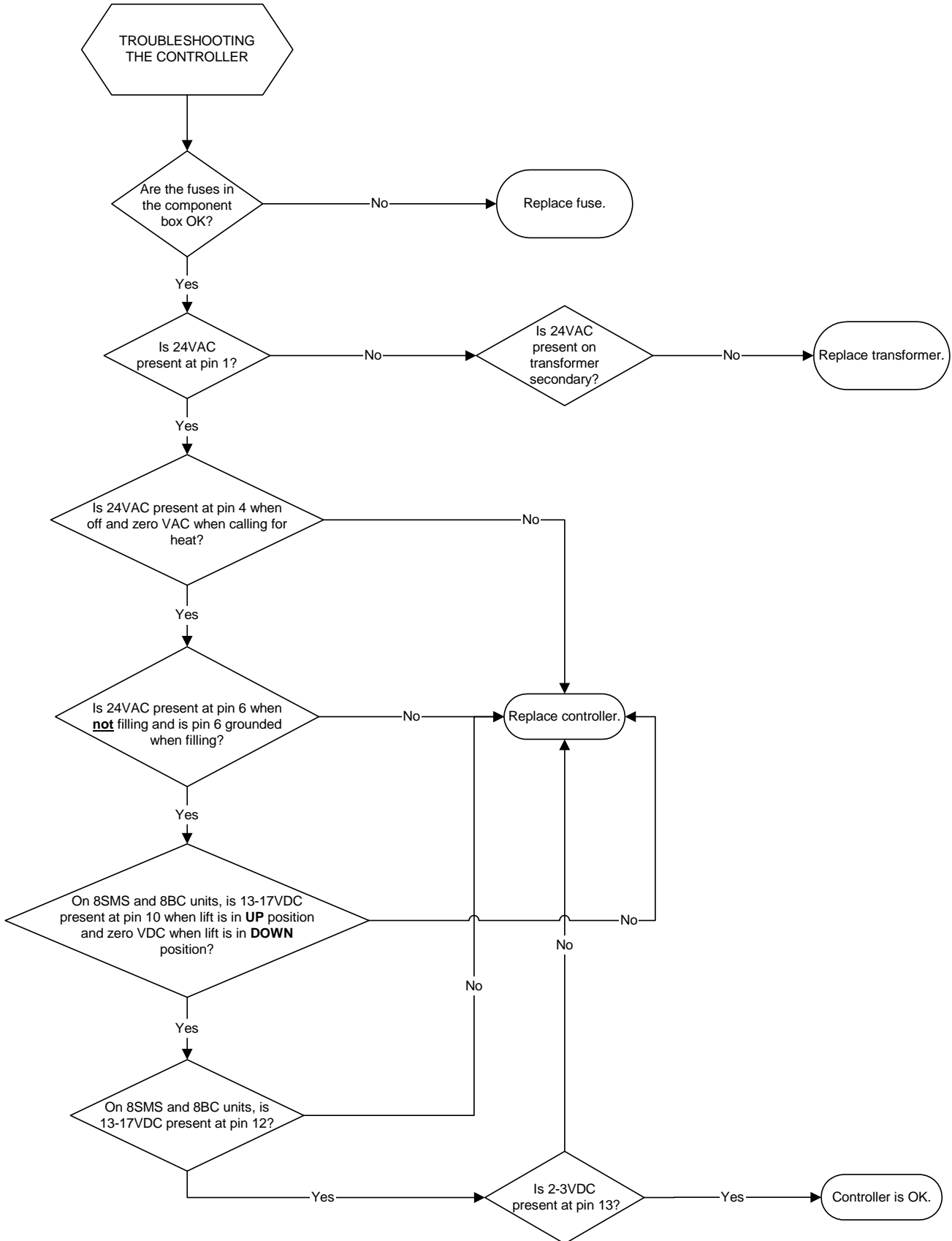

Technician Troubleshooting Guides (Continued)

Before performing the following checks, disconnect the unit from the electrical power source and check all wiring connections involved to ensure they are secure.

Each of the following checks is to be performed with the unit connected to the electrical power supply, with the controller on and calling for heat, and with enough water in the cookpot to cover the lower water level sensor.

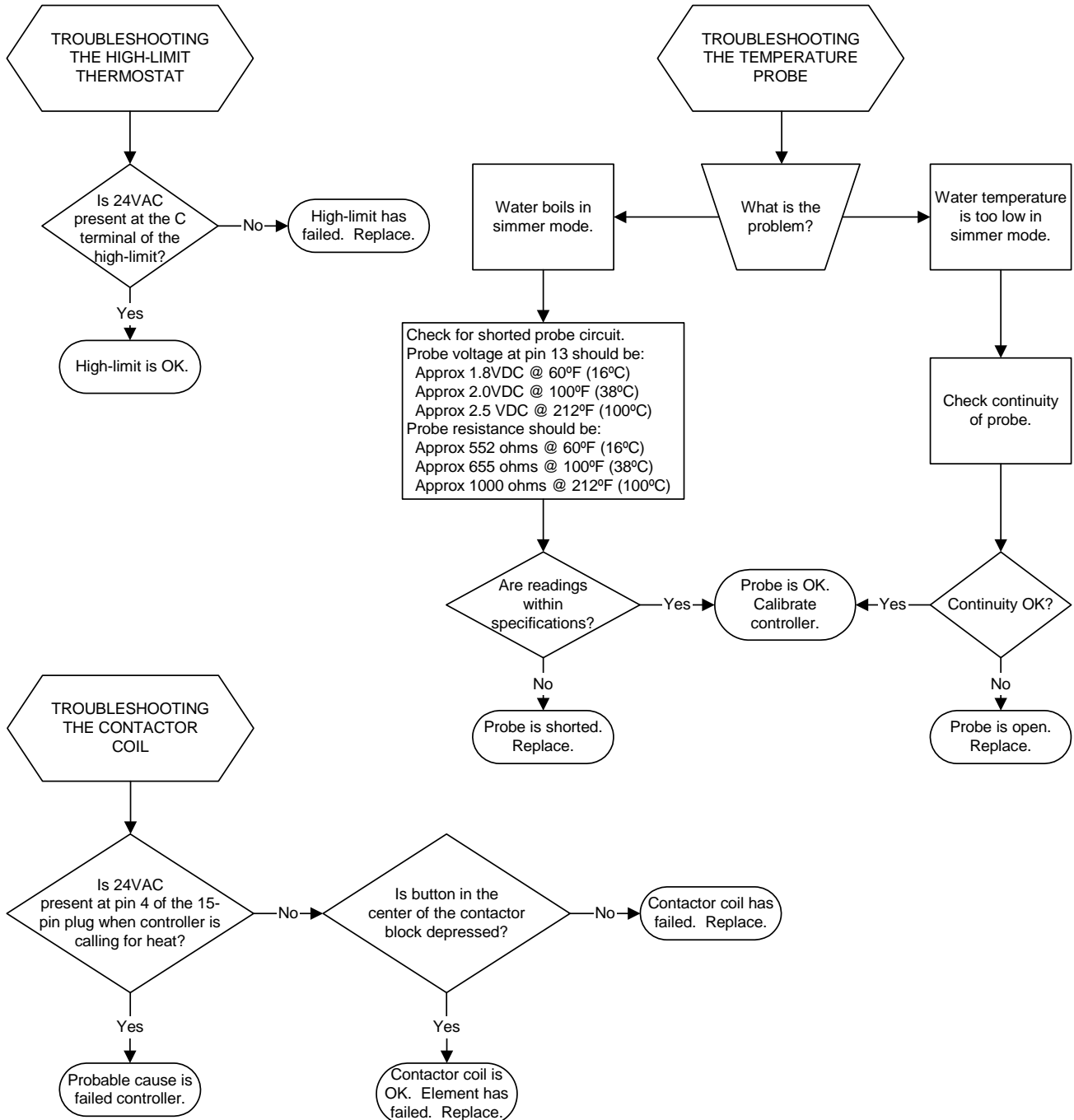

6.5 Wiring Diagrams

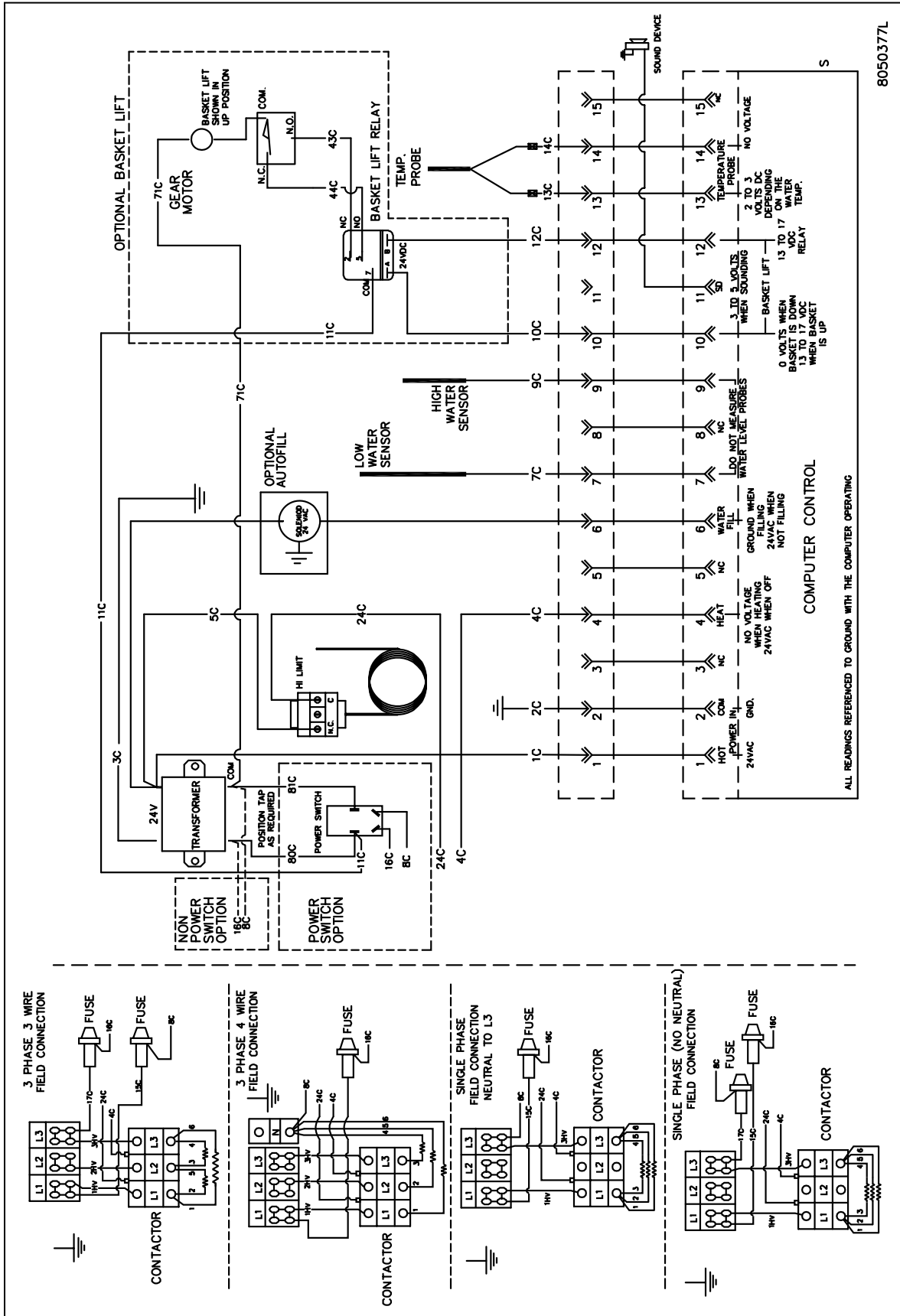

ELECTRIC COOKERS 8SMS, 8BC AND 8C

CHAPTER 7: PARTS LIST

7.1 Accessories

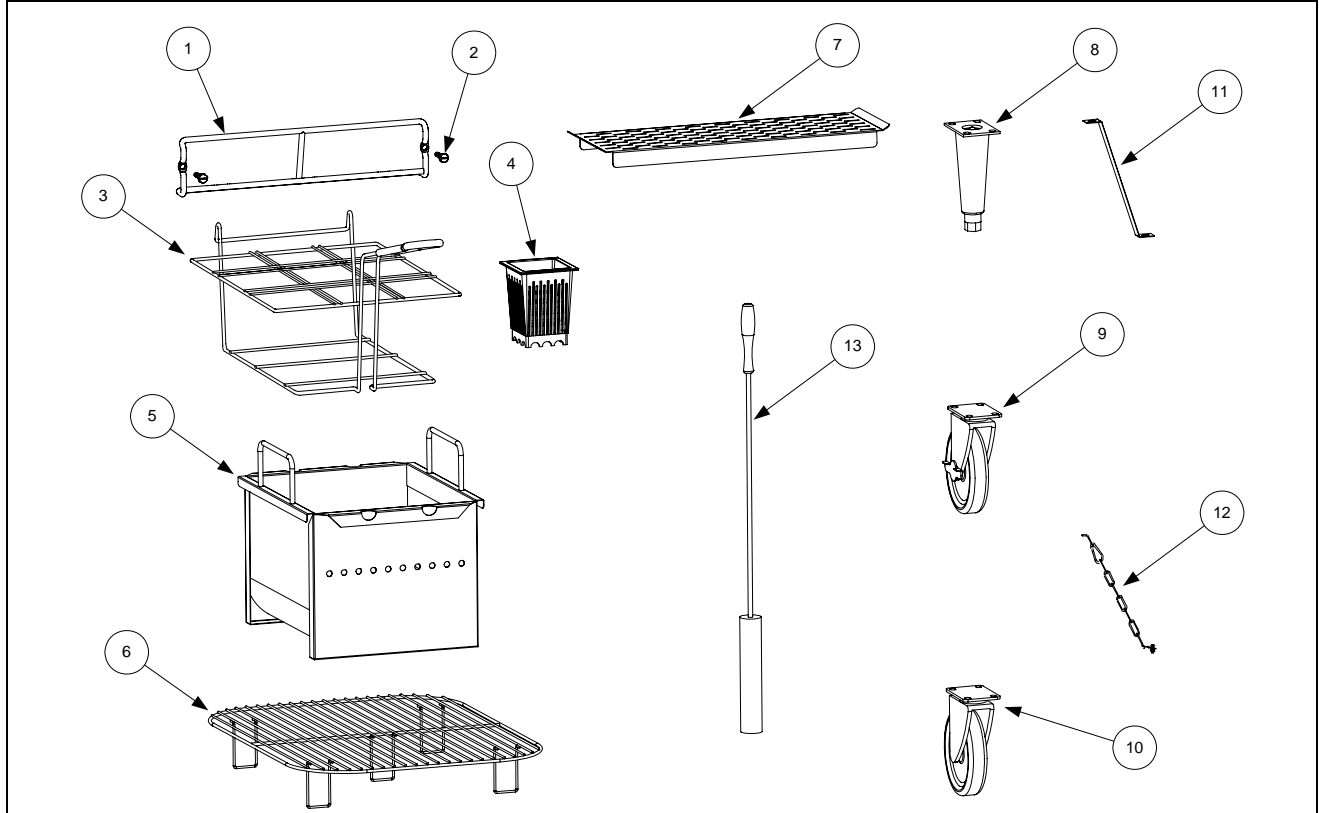

ITEM	PART #	COMPONENT
1	810-2112	Basket Hanger, Wire Form
2	809-0171	Basket Hanger Screw
3	803-0155	Holder, Portion Cup
4	803-0018	Cup, Portion
5	823-1662	Basket, Bulk Product
6	803-0167	Rack, Basket Support
7	910-2545	Strainer
8	806-3811	Legs, Package of 4 Adjustable
9	810-0357	Caster w/Brake
10	810-0356	Caster w/o Brake
*	826-1113	Kit, Leg/Caster Mounting (1 kit required per leg or caster)
11	826-1095	Kit, Anchor Strap (for use w/Cookers equipped with legs)
12	826-0900	Kit, Chain Restraint (for use w/Cookers equipped with casters)
13	803-0234	Brush, Probe Cleaning
*	823-2608	Connecting Strip, 8SMS

* Not illustrated

7.2 Basket Lift Components

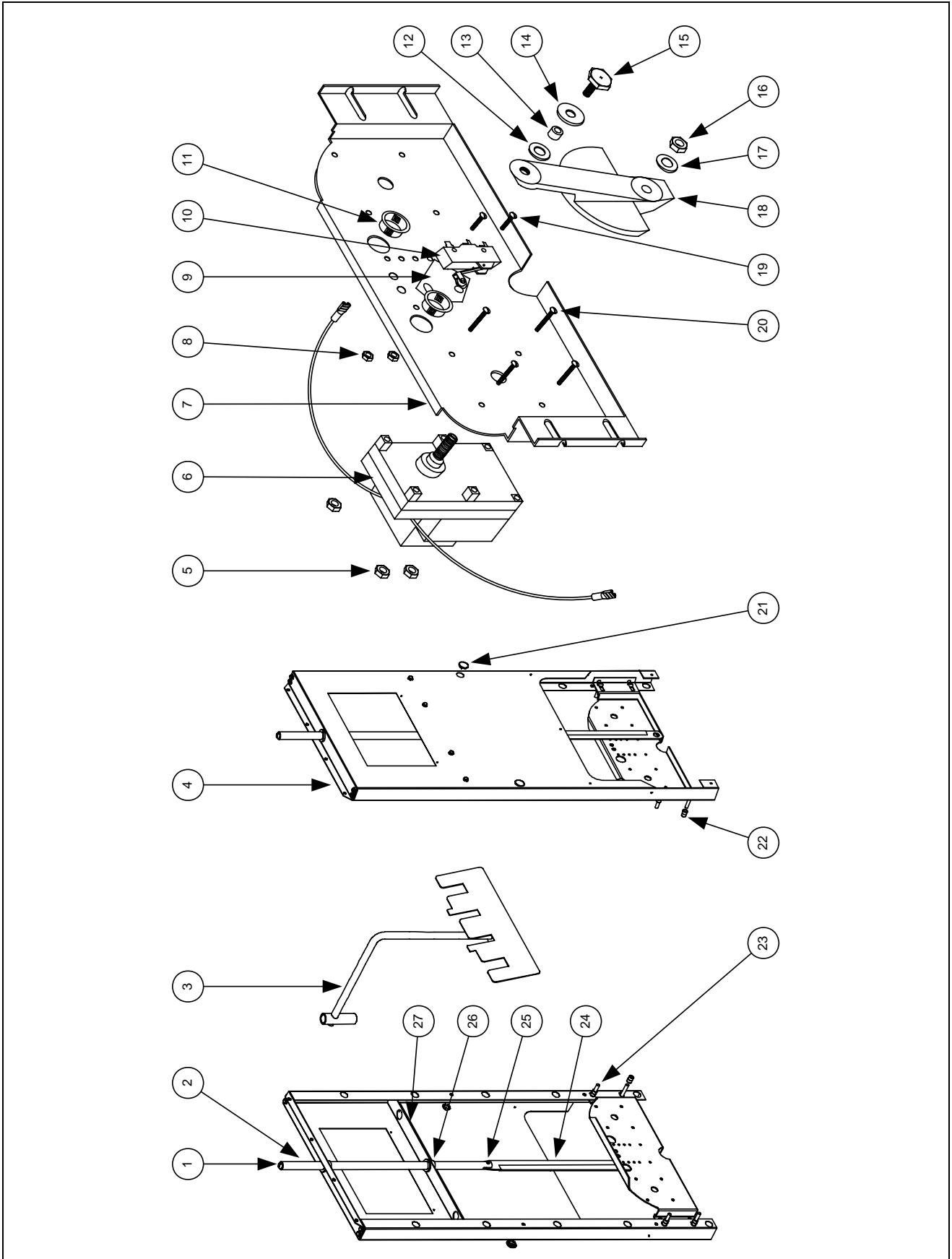

ITEM	PART #	COMPONENT
1	809-0127	Screw, 1/4-20 x 1/2-inch Round Head
2	810-0192	Rod, Basket Lift
3	823-1840	Arm, Basket Lift
4	900-7226	Enclosure, Basket Lift
5	809-0050	Nut, 8-32 Hex Head
6		Motor, Basket Lift
	807-0107	120 VAC
	807-0108	240VAC
7	920-3095	Mount, Basket Lift Motor
8	809-0049	Nut, 6-32 Hex Head
9	812-0138	Insulation, Paper
10	807-0240	Microswitch, BA-2RV22-D6
11	807-0124	Bushing, Plastic
12	809-0194	Washer, 5/16-inch SAE Flat
13	810-0220	Spacer, Tubular
14	809-0203	Washer, 1/2-inch Nylatron
15	809-0155	Screw, Leveling
16	809-0063	Nut, 3/8-inch Jam
17	809-0196	Washer, 3/8-inch SAE Flat
18	810-0052	Bellcrank
*	809-0480	Setscrew, 1/4-28 x 5/8-inch (secures Bellcrank to motor shaft)
19	809-0097	Screw, 6-32 x 1-inch Slotted Truss Head
20	809-0113	Screw, 8-32 x 1 1/2-inch Slotted Truss Head
21	810-0172	Button, Plug
22	809-0076	Nut, 1/4-20 Expansion
23	809-0134	Screw, 1/4-20 x 1 1/2-inch Round Head
24	920-3190	Link, Basket Lift
25	810-0170	Pin, 1/4-inch x 5/8-inch Spring Dowel
26	813-0035	Bushing, Bronze
*	809-0082	Ring, Retaining (secures bronze bushing 813-0035 in place)
27	900-4266	Angle, Bushing Support

* Not illustrated

7.3 Cabinetry

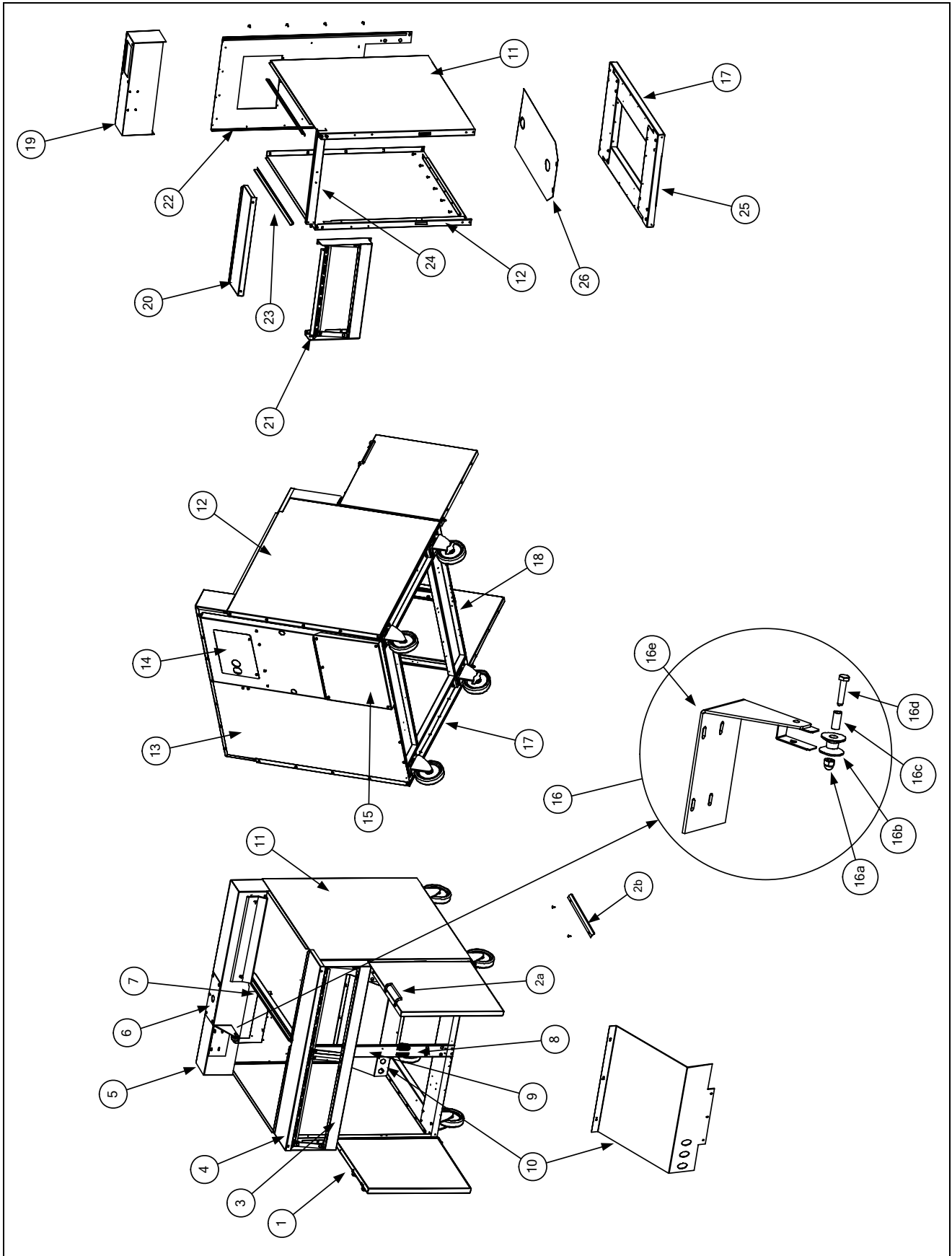

ITEM	PART #	COMPONENT
1	806-9744SP	Door Assembly (does not include handles)
2a	810-1402	Handle, Wireform Door (<i>cannot replace 210-9214</i>)
2b	210-9214	Handle, Eurolook Door (<i>cannot replace 810-1402</i>)
*	809-0266	Screw, Door Handle
*	810-1508	Hinge Bracket, Door
*	806-4487SP	Pin Assembly, Door
*	826-1343	Spring, Door Pin
3	806-4735SP	Frame Assembly, 8SMS Control Panel
*	910-4308	Blank Control Panel (used on rinse tank side of 8SMS)
4	910-7205	Top Cap, 8SMS
5	823-2609	Flue Cap, 8SMS
6	910-0207	Plate, Faucet Mounting (all models)
7	900-7202SP	Divider, 8SMS Cabinet
8	810-1105	Magnet, Door
9	900-7198	Post, 8SMS Door
10	900-4334	Shield, 8SMS Basket Lift Motor
11		Side, Right (all models)
	902-7167SP	Painted Steel
	912-7167SP	Stainless Steel
12		Side, Left (all models)
	901-7167SP	Painted Steel
	911-7167SP	Stainless Steel
13	900-7201SP	Panel, 8SMS Cabinet Back
14	900-4766	Panel, Basket Lift Upper Access (all models)
15	900-4351	Panel, Basket Lift Lower Access (all models)
*	900-7199SP	Brace, 8SMS Cabinet Top
*	900-1536	Bracket, Top Half Pot Hold Down (all models)
*	900-1537	Bracket, Top Half Pot Hold Down (all models)
16	806-5067SP	Guide Assembly, Basket Lift (all models)
16a	809-0047	Nut, Cap
16b	810-0194	Roller
16c	810-0374	Spacer
16d	809-0508	Bolt, 1/4-20 x 1 1/4-inch
16e	823-1803	Bracket
17	900-7156SP	Channel, Base Side (all models)
18	900-7200SP	Channel, 8SMS Base Front and Rear
*	806-5209SP	Pad Assembly, Leg or Caster Mounting (all models)
19	823-1714	Flue Cap, 8BC/8C
20	910-1514	Top Cap, 8BC/8C
21	806-4725SP	Frame, 8BC/8C Control Panel
22	900-7155SP	Panel, 8BC/8C Cabinet Back
23	900-7277	Stiffener, Cabinet Side (all models)
24	900-4279SP	Brace, 8BC/8C Cabinet Top
25	900-4280SP	Channel, 8BC/8C Base Front and Rear
26	900-7848	Shield, 8BC/8C Vapor

* Not illustrated

7.4 Cookpot and Rinse Tank Components

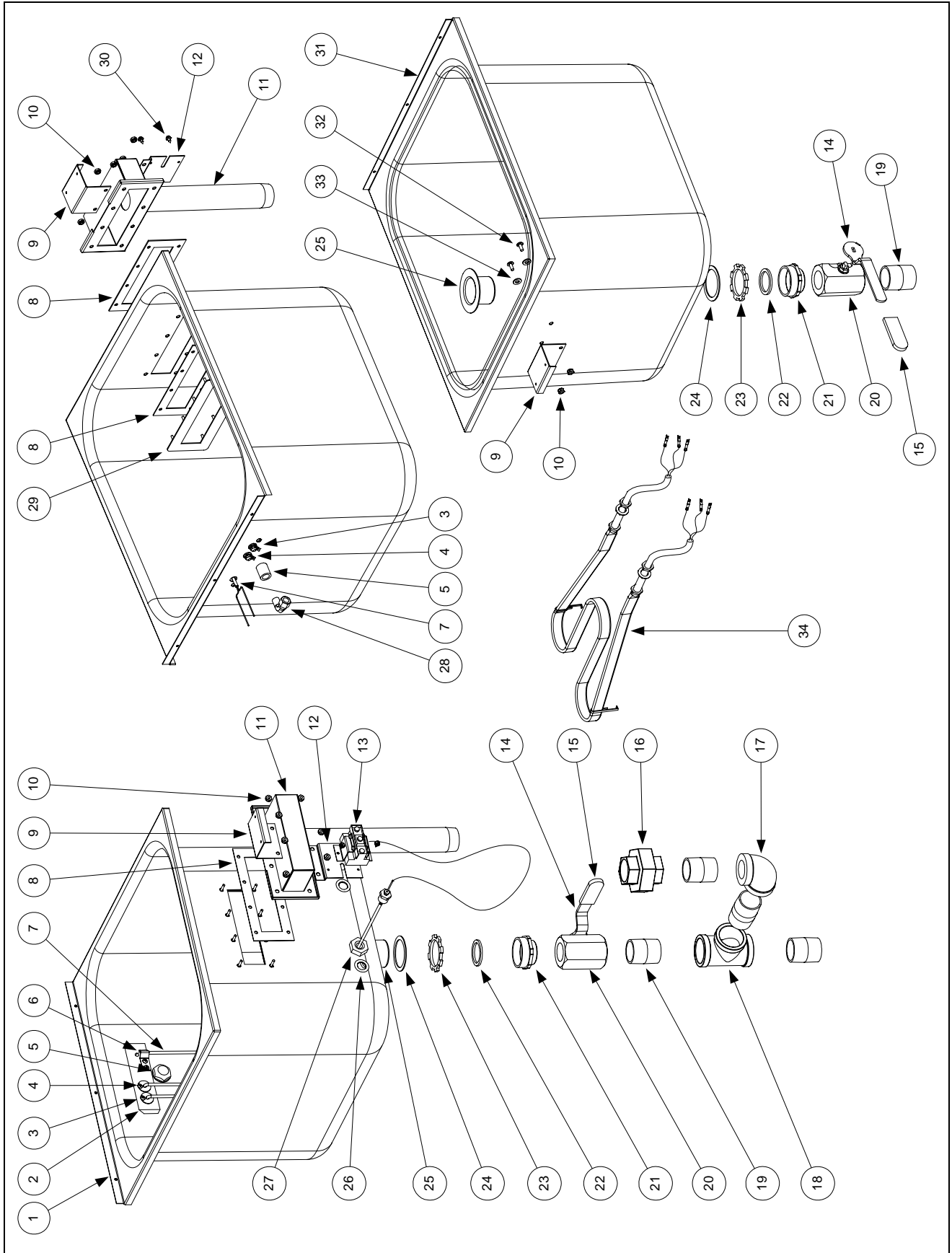

ITEM	PART #	COMPONENT
1	810-0698	Cookpot, 8SMS/8BC/8C
2	810-1697	Block, Probe
*	826-1081	Kit, Probe Block (old style with pins and cover)
*	823-2791	Cover, Probe Block
*	823-1942	Cover, Probe (old style with holes for pins)
3	823-1920	Sensor, Lower Water Level (approximately 7 inches long)
4	823-1921	Sensor, Upper Water Level (approximately 4¼ inches long)
*	809-0193	Washer, ¼-inch Nylon (used on water level sensors)
*	807-0037	Tab, Push-on Male (used on water level sensors)
5	810-0713	Nozzle, Spray
6	910-1804	Bracket, Temperature Probe Retaining
*	809-0357	Screw, #6 x ⅜-inch (used to secure sensors and probe bracket in place)
7	806-4764	Temperature Probe (with connectors)
8	816-0113	Gasket, Overflow Drain
9	900-1537	Bracket, Pot Hold Down Bottom
10	809-0256	Nut, 10-32 Keps Hex
11	823-1711	Drain, Overflow
12	900-5675	Bracket, High-Limit Thermostat Mounting
13	826-1601	Thermostat, High-Limit (includes high-limit, gasket, and tie wrap)
*	809-0567	Tie Wrap, Metal (secures Hi-Limit Thermostat to Element)
14	810-1826	Handle, Drain Valve
15	814-0047	Sleeve, Red Valve Handle (with logo)
16	813-0395	Union, 1¼-inch NPT
17	813-0070	Elbow, 1¼-inch x 90° NPT
18	813-0394	Tee, 1¼-inch NPT
19	813-0391	Nipple, 1¼-inch NPT Close
20	810-1825	Valve, 1¼-inch NPT Drain
21	813-0397	Reducer, 1½-inch Sink to 1¼-inch NPT
22	816-0221	Washer, 1¾-inch Sink
23	809-0464	Nut, 1½-inch Conduit
24	809-0465	Washer, Sink Drain
25	813-0396	Drain, 1½-inch Sink (includes item 23)
26	809-0204	Washer, ⅝-inch Flat
27	809-0444	Nut, Hex Jam
28	813-0302	Elbow, ¼-inch NPT to ⅜-inch Tube 90° Compression
29	823-1657	Fascia, Overflow Drain
30	809-0360	Screw, #8 x ⅜-inch Hex Washer Head
31	810-0699	Tank, Rinse
32	809-0270	Screw, 10-32 x ½-inch Truss Head
33	809-0192	Washer, ¼-inch Lock with external teeth
34		Element, 8kW, 1- or 3-Ø (includes mounting washer and nut and standoff)
	826-1795	208VAC
	826-1797	230VAC
	826-1798	240VAC
	807-1729	480VAC (requires two teflon washers, 809-0204)

* Not illustrated

7.5 Electrical Components and Controllers

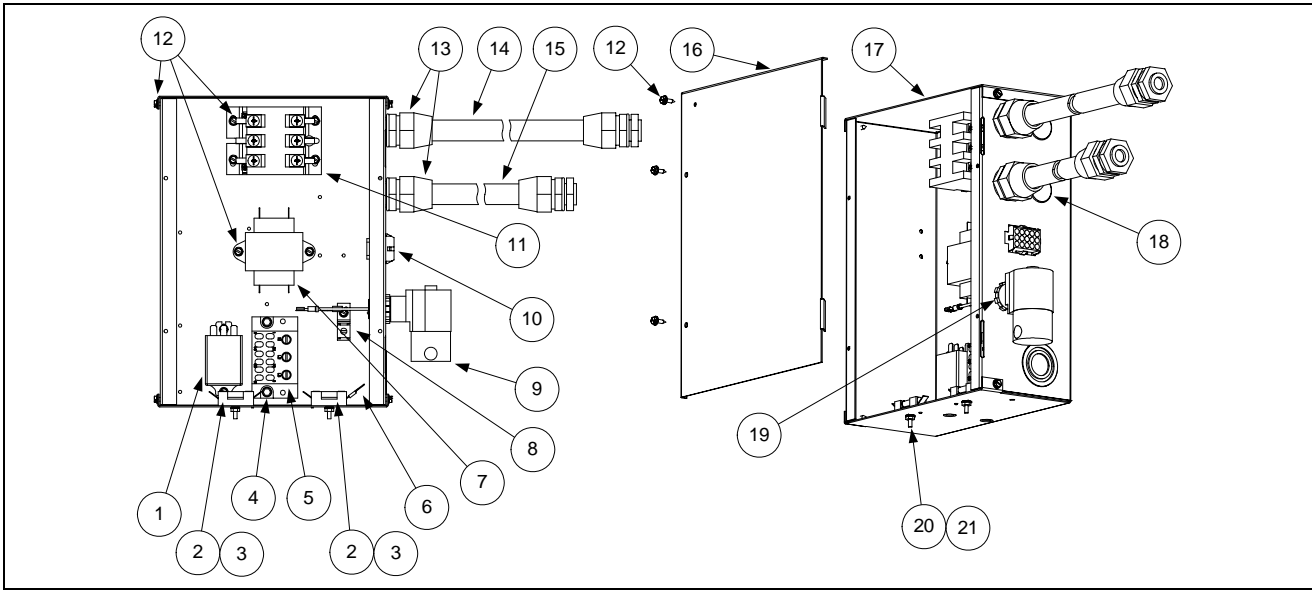

ITEM	PART #	COMPONENT
1	807-1396	Relay, 24VDC
2	807-1308	Holder, Fuse
3	807-1555	Fuse, 5 Amp
4	809-0362	Screw, #8 x 1¼-inch Hex Head
5	807-0878	Block, Terminal
6	807-0263	Terminal, Split
7	807-0680	Transformer, 208/240VAC – 24VAC
8	807-0070	Terminal, Ground Lug
9	806-4770	Valve Assembly, Solenoid
10	807-0875	Connector, 15-pin Female
11	810-1202	Contactor, 40 Amp 3 Pole
12	809-0361	Screw, #8 x ½-inch Hex Head
13	807-1292	Fitting, Plastic Conduit
14	812-0994	Conduit, ½-inch Plastic (17 inches long)
15	812-0992	Conduit, ½-inch Plastic (15 inches long)
16	900-7853	Cover, Component Box
17	823-1820	Box, Component
18	810-0044	Button, ⅞-inch Plug
19	809-0454	Nut, ½-inch Conduit
20	809-0096	Screw, 6-32 x ⅝-inch
21	809-0250	Nut, 6-32 Keps
*	806-5332	Cordset, Basket Lift (used with 480/120VAC dual-voltage units only)
*	WIR0013SP	Wire Assembly, 8SMS Contactor Box
*	806-4702	Cable, 8SMS Controller
*		Controller, 8SMS
	106-0371	CE and non-CE with AutoFill and AutoSkim
	106-0373	CE and Non-CE with AutoFill but without AutoSkim
	106-0374	CE and Non-CE without Autofill or Autoskim

* Not illustrated.

7.6 Water Supply Components

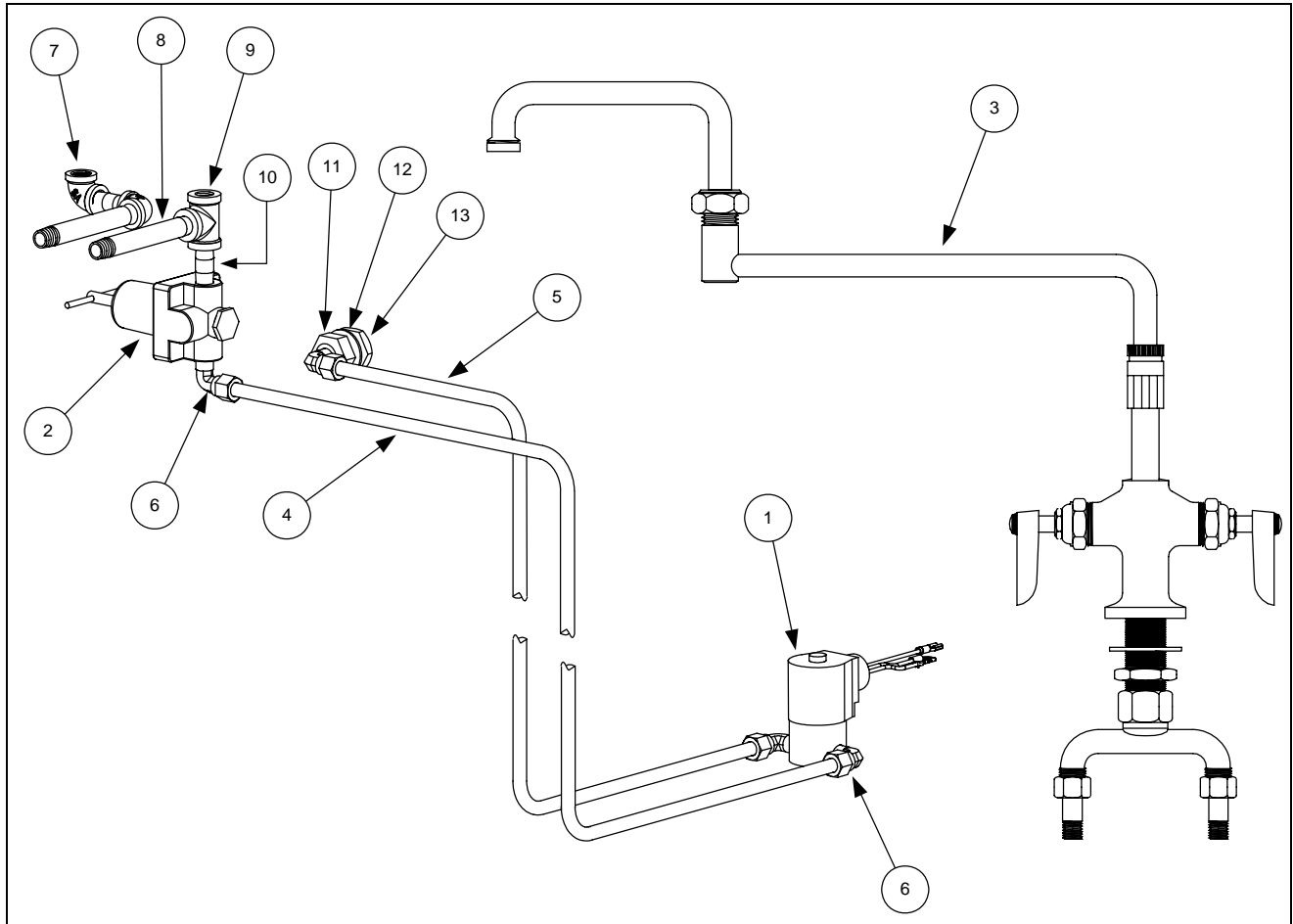

ITEM	PART #	COMPONENT
1	806-4770	Solenoid Assembly, Autofill
2	810-1208	Regulator, Water Pressure
3	813-0412	Faucet, Double Jointed
*	826-1132	Kit, Faucet Repair (contains two valve assemblies)
4	900-2114	Tube, Copper Water Supply
5	910-2496	Tube, Stainless Steel Autofill
6	813-0302	Elbow, Brass $\frac{3}{8}$ -inch Tube to $\frac{1}{4}$ -inch NPT (w/Compression Nut)
7	813-0448	Elbow, Brass $\frac{1}{4}$ -inch x 90° NPT
8	813-0473	Nipple, Brass $\frac{1}{4}$ -inch x 4-inch NPT
9	813-0449	Tee, Brass, $\frac{1}{4}$ -inch NPT
10	813-0471	Nipple, Brass $\frac{1}{4}$ -inch x 1.5-inch NPT
11	809-0444	Nut, $\frac{3}{4}$ -10 Hex Head Jam
12	816-0114	Gasket, Spray Nozzle
13	810-0713	Nozzle, Spray
*	826-1135	Kit, Non-Autofill to Autofill Conversion

* Not illustrated



Shipping Address: 8700 Line Avenue, Shreveport, Louisiana 71106

TEL 1-318-865-1711

FAX (Parts) 1-318-219-7140

(Tech Support) 1-318-219-7135

PRINTED IN THE UNITED STATES

SERVICE HOTLINE
1-800-551-8633

819-5246
MAR 11